



Asia-Pacific  
Economic Cooperation



Asia-Pacific  
Legal Metrology Forum

# Handbook on Automated Sphygmomanometers

APEC/APLMF Training Courses in Legal Metrology  
(CTI 11/2006T)

July 17 – 21, 2006  
Taipei, Chinese Taipei

**APEC Secretariat**

35 Heng Mui Keng Terrace  
Singapore 119616.  
Tel: +65-6775-6012, Fax: +65-6775-6013  
E-mail: [info@apcc.org](mailto:info@apcc.org)  
Website: [www.apcc.org](http://www.apcc.org)

**APLMF Secretariat**

AIST Tsukuba Central 3-9  
1-1-1 Umezono, Tsukuba, Ibaraki 305-8563, Japan  
Tel: +81-29-861-4362, Fax: +81-29-861-4393  
E-mail: [sec@aplmf.org](mailto:sec@aplmf.org)  
Website: [www.aplmf.org](http://www.aplmf.org)

© 2006 APEC Secretariat  
APEC# 206-CT-04.2 ISBN 9903094-4-8

**February 2007**



Seminar on Automated Sphygmomanometers  
July 17 – 21, 2006

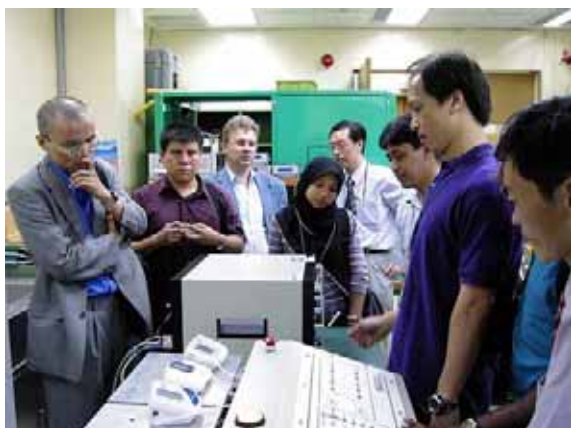

# Contents

<b>1 Foreword</b> .....	1
<b>2 Summary Report</b> .....	3
<b>3 Agenda</b> .....	5
<b>4 Participants List</b> .....	9
<b>5 Lecture</b>	
<u>Dr. Stephen Mieke</u>	
OIML R 16-2 “Non-invasive Sphygmomanometer”	
Medical background .....	11
Techniques to measure indirectly the blood pressure.....	13
Requirements, standards, etc for sphygmomanometers .....	16
Requirements for automated sphygmomanometer (pattern approval) .....	17
Requirements for automated sphygmomanometer (verification).....	26
Difference between OIML R16-2 and EN 1060 .....	30
Traceability of Medical Device.....	33
European standards on sphygmomanometers .....	36
European simulator to test automated sphygmomanometers	
Accuracy requirements .....	51
Why simulators? .....	52
Design of simulators .....	53
Results from measurements with simulators .....	60
Outlook .....	60
Current Situation in Germany for sphygmomanometers .....	62
<u>Mr. Shinichi Bunryou</u>	
Type Approval System for sphygmomanometers in legal metrology, Japan	
Introduction on measurement law in Japan .....	67
Why need passing the verification?.....	70
How to pass verification and why need type approval.....	71
Automated sphygmomanometers	
Introduction.....	74
Mode for testing.....	76
<u>Mr. Porson Fu</u>	
Electronics Testing Center, Taiwan .....	78
<u>Dr. Chang-Chyi Lin</u>	
NIBP monitor .....	89
<u>Mr. Chen-Chuan Hung</u>	
The Accuracy and Traceability of Non Invasive Automated Sphygmomanometers.....	96

**6 Reports from the Trainees**

- 6.1 Cambodia (This is a non-APEC economy.) ..... 103
- 6.2 Indonesia..... 106
- 6.3 Malaysia..... 110
- 6.4 Mongolia (This is a non-APEC economy.) ..... 114
- 6.5 Papua New Guinea ..... 119
- 6.6 Peru..... 122
- 6.7 Philippines ..... 125
- 6.8 Chinese Taipei ..... 128
- 6.9 Viet Nam..... 137

## Foreword

This booklet is one of the outcomes of the APEC Seminars and Training Courses in Legal Metrology titled “Seminar on Automated Sphygmomanometers” which was held on July 17 – 21, 2006 at the Howard International House in Taipei, Chinese Taipei. This course was organized as a follow-up of “Seminar on Sphygmomanometers” conducted in August 2004 in Chinese Taipei. This time, we put more focus on the comparison and information exchange among the participated economies on the current trends of sphygmomanometer’s metrological standards practiced in the APLMF member economies, while the previous seminar was aimed at building a fundamental understanding on its international standards.

This seminar was organized by the Asia-Pacific Legal Metrology Forum (APLMF) and Bureau of Standards, Metrology and Inspection (BSMI), Ministry of Economic Affairs of Chinese Taipei with a support fund of APEC Trade and Investment Liberalization and Facilitation (APEC-TILF) program, CTI-11/2006T. It was also supported by: (1) The Center for Measurement Standards (CMS), The Industrial Technology Research Institute (ITRI); (2) Electronic Testing Center (ETC), Chinese Taipei; (3) Physikalisch-Technische Bundesanstalt (PTB), Germany and (4) National Metrology Institute of Japan (NMIJ). Having this result, I would like to extend my sincere gratitude to Dr. Jay San Chen of BSMI, Dr. Chi-Sheng Chang of CMS, Mr. David Y. Wang of ETC, Dr. Stephan Mieke of PTB Germany, Mr. Shinichi Bunryou of NMIJ, Mr. Chen-Chuan Hung of CMS and Dr. Chang-Chyi Lin of Cheng Hsin Rehabilitation Medical Center. Also, special thanks should be extended to the APEC Secretariat for their great contributions.

We have conducted the surveys among the APEC member economies concerning seminar and training programs in legal metrology to find their needs as well as possible human resource available in the region. The survey shows that there is a strong need for a training course or seminar on sphygmomanometers in legal metrology. Medical measurement has become a great interest of the member economies due to the extended average life expectancy. Plus, medical measuring instruments, such as sphygmomanometers and clinical thermometers are getting widely used not only in medical facilities but also at home. In particular, portable measuring devices are expected to be widely used in near future. Where, there is one big problem concerning the reliability and mutual acceptability of measured results by such instruments. Now, standards and regulations for such instruments need to harmonize among APEC economies. However, our survey also shows that there are not enough human resources for developing economies to ensure reliability on medical instruments. Such seminar and training course could be effectively carried out under the arrangements of the international organizations APEC and APLMF.

Main target of this training course was to assist APEC members to develop common understanding about the current standards and regulations on automated sphygmomanometers

and thus meet the APEC objective to harmonize metrology legislation with OIML international recommendations. The actual contents of the seminar were focused on learning different approaches used in other economies concerning the standards and regulations on sphygmomanometers.

In view of these situations, the seminar on automated sphygmomanometers provides opportunity to the Asia-Pacific region for a sure basis of confidence in Legal Metrology related to medical measurements. I would say certainly that this is a valuable starting step to fruitful activities of medical measurements in the Asia-Pacific region.

I am really pleased to have this outcome from the training course and again deeply appreciate invaluable voluntary efforts of the APEC and APLMF secretariats.

February 27, 2007

A handwritten signature in black ink, appearing to read "Akira Ooiwa". The signature is fluid and cursive, with the first name "Akira" and the last name "Ooiwa" clearly distinguishable.

Dr. Akira Ooiwa

APLMF President

## **Summary Report on the Seminar on Non-invasive Automated Sphygmomanometers**

Chinese Taipei conducted a survey on non-invasive automated sphygmomanometers in 2003 then hosted a seminar on non-invasive automated sphygmomanometers in late August 2004 according to the result of the survey. The seminar was supported by APEC and APLMF. NMIJ also gave very helpful support. All participants satisfied with the results. Therefore, APLMF asked the Bureau of Standards, Metrology and Inspection (BSMI), Chinese Taipei organizes another seminar on non-invasive automated sphygmomanometers from July 17 to 21 in 2006. As usual, BSMI worked with APLMF Secretariat closely to make sure the seminar would reach its original goal.

Eight participants from Cambodia, Indonesia, Malaysia, Mongolia, Papua New Guinea, Peru, Philippines and Viet Nam participated with support either from APEC or APLMF, and sixteen participants from the host economy attended the seminar. All of them benefited a great deal from three prominent speakers in the field of the legal control issues in sphygmomanometers at the seminar, i.e. Dr. Stephan Mieke, Head of Working Group of Standards for Medical Measuring Techniques, PTB, Germany and the Secretariat of TC18: Medical measuring instruments, OIML; Mr. Shin- Bunryou, a senior expert of NMIJ, Japan; and Mr. Chen-Chuan Hung, Researcher, National Measurement Laboratory. Dr. Mieke lectured on OIML Recommendation 16-2 and the difference between OIML R 16-2 and EN 1060. He also talked about the European Standards of sphygmomanometers and current situation in Germany and also brought the concept of sort traceability. Mr. Bunryou introduced the relative regulations in Japan and shared his experience in the field of type approval of sphygmomanometers in the three- hour presentation. Mr. Hung briefed the relative regulation in Chinese Taipei. In addition, Dr. Chang-Chyi Lin, a physician of Cheng Hsin Rehabilitation Medical Center in Taipei, presented the concept of the application of sphygmomanometers in clinical practice.

Three technical trips were arranged. The first trip was a visit to Electronics Testing Centre on 20th. Mr. Wang, the president of the centre, received all participants and expressed his welcome. His staffs let us observe their testing equipments for sphygmomanometers as well as the testing procedures for sphygmomanometers. They also answered the questions from participants. During the demonstration, Dr. Mieke gave a lot of useful comments to help participants understand the whole picture of the testing process. The second trip was a visit to the National Measurement Laboratory in Hsin-Chu. The scientists and engineers in the lab introduced the national measurement standards. On the following day, July 21st, all participants visited the 7th Division of BSMI. Mr. Chang, the director of the division, briefed the main tasks of his office, and the engineers demonstrated the procedures of verification for measurement instruments.

One of the most important objectives of the seminar was to establish friendship among participants from different countries working in this field. To achieve this objective, a welcome party was held at Howard Skyline Restaurant Taipei on the night of July 17. Looking through windows from the 44th floor where the restaurant is located, everyone enjoyed watching the amazing scenery of Taipei and took a lot of pictures. Certainly, all participants experienced delicious cuisine at this restaurant. Participants also visited a traditional Hakka restaurant in Hsin-

Chu before the trip to NML. Hakka society, basically emigrated from Southern Mainland China during Chin Dynasty to the island, is one of the main groups of Taiwanese society. This restaurant is famous for its architecture, garden and delicious dishes. It is a great place to learn about the history in the fancy true Hakka culture. A farewell dinner was held at the Caesar Park Hotel on the night of July 20th. In addition, all the participants visited Taipei 101, the tallest building in the world, and went up to Observation Station at the 89th floor to overlook Taipei City.

This seminar enhanced participants' understanding of OIML R 16-2 and other related standards, which certainly helped achieve the objective of APLMF to harmonize metrological standards among member economies and remove technical barriers to trade. We believe that the holding of such seminars is an effective method to promote APLMF goals, from which all member economies would benefit.

During the seminar, all participants presented the current legislations and controls of non-invasive automated sphygmomanometers in his/her country. The presentations have been posted on the APLMF website at [http://www.aplmf.org/training\\_courses/index.htm](http://www.aplmf.org/training_courses/index.htm).

Dr. Jay-San Chen  
Director General  
Bureau of Standards, Metrology and Inspection





Bureau of Standards,  
Metrology and Inspection



Asia-Pacific  
Economic Cooperation



Asia-Pacific  
Legal Metrology Forum

---

## **APEC/APLMF Seminars and Training Courses in Legal Metrology (CTI-11/2006T) Seminar on Automated Sphygmomanometers**

July 17 – 21, 2006  
at the Howard International House in Taipei, Chinese Taipei

### **Program**

#### **Organizers:**

1. Asia-Pacific Economic Cooperation (APEC)
2. Asia-Pacific Legal Metrology Forum (APLMF)
3. Bureau of Standards, Metrology and Inspection (BSMI),  
Ministry of Economic Affairs (M.O.E.A.)

#### **Supporting Organizations:**

1. The Center for Measurement Standards (CMS),  
The Industrial Technology Research Institute (ITRI)
2. Electronic Testing Center (ETC), Chinese Taipei
3. Physikalisch-Technische Bundesanstalt (PTB), Germany
4. National Metrology Institute of Japan (NMIJ),  
National Institute of Advanced Industrial Science and Technology (AIST)

#### **Main Objective of the Seminar:**

Some portable medical measuring instruments, such as clinical electrical thermometers and automated sphygmomanometers are getting to be widely used not only in medical facilities but also in private homes. However, there remain problems concerning the reliability and mutual acceptability of measured results by such instruments. Standards and regulations for such instruments are just starting to be under operation.

Main target of this seminar is to assist APEC and APLMF member economies to develop common understanding about the current standards and regulations on automated sphygmomanometers and thus meet the APEC objective to harmonize metrology legislation with OIML international recommendations. Officials in charge of type approvals and/or regulation of automated sphygmomanometers are expected to attend the seminar. Actual contents of the lecture would be focused on the understanding of basic construction of automated sphygmomanometers and current international or national standards and regulations related to the sphygmomanometers.

### **Venue and Accommodation:**

- **Howard International House Taipei**

30 HsinSeng South Road, Section 3, Taipei 106, Chinese Taipei,

Telephone: (886-2) 8369-1155

Fax: (886-2) 8369-1177

<http://3w.howard-hotels.com.tw/>

- **Accommodations:**

Accommodation for the participants will be prepared in the Howard International House on a request from the participant at a rate of **NT\$1700 (about US\$50)**. Please use the separated registration form to reserve the accommodations.

### **Speakers:**

- Dr. Stephan Mieke, Head, Standards for Medical Metrology, PTB
- Mr. Shinichi Bunryo, Dissemination Technology Division, NMIJ, AIST
- Mr. Chen-Chuan Hung, Measurement Standards & Technology Division, CMS, ITRI
- Dr. Chang-Chyi Lin, Cheng Hsin Rehabilitation Medical Center

### **Registration:**

- Fill the attached “**Registration Form**” and send it to the APLMF secretariat by **June 23, 2006**.

### **Passport, Visa and Vaccinations:**

- Every participant will be required to hold a valid passport and valid visa for entry into Chinese Taipei. Some foreign nationals are granted an automatic visa upon arrival. Please check with your local Trade and Culture Office of Chinese Taipei regarding visas and vaccinations.
- If you find out that you need visa, please fill the attached “**Visa Assistance Form**” and send it to the host (BSMI) by **July 7, 2006**. On your request, the host will send an official ‘letter of invitation’ to participants for visa application at the Trade and Cultural Offices of Chinese Taipei in the participants’ countries.
- For more information, please visit the Ministry of Foreign Affairs’ web-site at <http://www.mofa.gov.tw/mofa91/web/welcome.html> or the Bureau of Consular Affairs’ web-site at <http://www.boca.gov.tw/english/index.htm>.

### **Access Information:**

- **Howard International House Taipei** is about 45 kilometres from Chiang Kai-Shek International Airport. We recommend you to take the “Air Bus” that runs every 30 minutes, and it would take about 70 minutes to get to from CKS Airport to downtown Taipei, at a cost of NT\$140. You should get off at the Howard Hotel, and ask the front desk to arrange a taxi to the Howard International House Taipei (公務人力發展中心, 台北市新生南路3段30號) cost about NT\$150.
- **Taxis** are convenient and relatively inexpensive. However, most taxi drivers in Taipei do not speak English. It is most helpful to have your intended locations written in Chinese for the driver.

### **Currency and Credit Cards:**

The currency in Chinese Taipei is New Taiwan Dollars. Coin denominations are NT\$1, NT\$5, NT\$10, NT\$20, and NT\$50. Bill denominations are NT\$100, NT\$200, NT\$500, NT\$1000, and NT\$2000. The current exchange rate for NT dollar is about US\$1= NT\$32.5. Foreign currency and traveler's checks can be exchanged at most banks. International credit cards such as VISA, American Express, Diner Club or Master Card are accepted in most hotels, restaurants, department stores, and shops.

### **Climate and Clothing:**

The weather in Taipei in July is very hot. The average temperature is about 31 degree Centigrade. Please log on the website of the Central Weather Bureau (<http://www.cwb.gov.tw/V5e/index.htm>) for your information.

### **Electricity Supply:**

The Electricity supply in Chinese Taipei is 110 V/60 Hz. In some cases, 220 V/60 Hz might also be available. Always check the power supply if you have any questions.

### **Local Time:**

Local time in Chinese Taipei is GMT+ 8hrs.

### **Contact Persons about the Seminar:**

- **APLMF Secretariat** (registration and travel support)  
Tsuyoshi Matsumoto & Ayako Murata  
APLMF Executive Secretary  
NMIJ/AIST Tsukuba Central 3-9, 1-1-1 Umezono, Tsukuba, Ibaraki 305-8563, Japan  
Tel: +81-298-61-4362  
Fax: +81-298-61-4393  
E-mail: [e.sec@aplmf.org](mailto:e.sec@aplmf.org) & [sec@aplmf.org](mailto:sec@aplmf.org)
- **Host in Chinese Taipei** (visa assistance, accommodation, venue and access information)  
Ms. Meggie Chu  
Bureau of Standards, Metrology and Inspection (BSMI),  
Ministry of Economic Affairs (M.O.E.A.)  
7F, No.20, Nanhai Road, Taipei 100, Chinese Taipei  
Tel: + 886-2-2396-3360 ext 738  
Fax: + 886-2-2343-1976  
E-mail: [meggie.chu@bsmi.gov.tw](mailto:meggie.chu@bsmi.gov.tw)

## Final Program

<b>July 17 Monday</b>  (Room 101)	08:30–09:00	<i>Registration</i>
	09:00–09:15	Opening ceremony Welcoming address (Dr. Jay-San Chen, Director General of BSMI)* Opening address (Dr. Matsumoto, APLMF Executive Secretary)
	09:15–09:20	Taking a group picture
	09:20–10:00	<i>Coffee break and a press conference</i>
	10:00–12:00	OIML R 16-2 “Non-Invasive Sphygmomanometer” (Dr. Mieke) (1) Medical background / (2) Techniques to measure indirectly the blood pressure
	12:00–13:30	<i>Lunch break</i>
	13:30–15:20	(3) Requirements, standards etc. for sphygmomanometer / The traceability on automated sphygmomanometer (Dr. Mieke)
	15:20–15:40	<i>Coffee break</i>
	15:40–17:00	(4) Requirements for automated sphygmomanometer (pattern approval) (Dr. Mieke)
	18:00	<i>Leave hotel lobby for the dinner by bus</i>
	18:30–21:00	<i>Welcome dinner hosted by the BSMI at the Howard Skyline Restaurants Taipei, 66 Chunghsiao W. Rd., Sec. 1, 44/45F, Taipei</i>
<b>July 18 Tuesday</b>  (Room 101)	09:00–10:20	(4) Requirements for automated sphygmomanometer (pattern approval) (Dr. Mieke)
	10:20–10:40	<i>Coffee break</i>
	10:40–12:00	(5) Requirements for automated sphygmomanometer (verification) (Dr. Mieke)
	12:00–13:30	<i>Lunch break</i>
	13:30–15:20	(6) Difference between OIML R16-2 and EN 1060 (Dr. Mieke) (7) European standards on sphygmomanometers (Dr. Mieke)
	15:20–15:40	<i>Coffee break</i>
15:40–17:00	(8) European simulator to test automated sphygmomanometers (Dr. Mieke)	
<b>July 19 Wednesday</b>  (Room 101)	09:00–10:20	Clinical application of blood pressure measurement (Dr. Lin)
	10:20–10:40	<i>Coffee break</i>
	10:40–12:00	(9) Current situation in Germany on sphygmomanometers (Dr. Mieke)
	12:00–13:30	<i>Lunch break</i>
	13:30–15:20	Type approval system for Sphygmomanometers in Japan (Mr. Bunryo)
	15:20–15:40	<i>Coffee Break</i>
15:40–17:00	Type approval system for Sphygmomanometers in Japan (Mr. Bunryo)	
<b>July 20 Thursday</b>  (ETC & CMS/ITRI)	08:30	<i>Leave hotel lobby for the technical visit by bus</i>
	09:30–11:00	Technical visit to Electronic Testing Center (ETC) in Taoyuan (Mr. David Wang, Mr. Shih-Ming Chang (ETC) & host staffs)
	12:00–13:30	<i>Lunch break at a restaurant in Golden Mountain Fine Arts &amp; Life Style in Hsinchu</i>
	13:45–16:00	Technical visit to Measurement Standards & Technology Division, CMS, ITRI in Hsinchu (Dr. Chi-Sheng Chang, Mr. Chen-Chuan Hung (CMS) & host staffs)
	17:20–18:15	<i>After going back to the hotel, visit the Chiang Kai-shek Memorial Hall</i>
	18:30–21:00	<i>Farewell dinner hosted by the BSMI at the Hotel Caesar Park Taipei, 38 Chung Hsiao W. Rd., Sec. 1, Taipei</i>
<b>July 21 Friday</b>  (BSMI & Taipei city)	8:30	<i>Leave for the Headquarters of BSMI at 4 Sec. 1, Chinan Road, Taipei by bus</i>
	09:00–10:00	Summary including country report by a trainee from each economy (all participants)
	10:00–10:25	<i>Coffee break</i>
	10:25–12:10	Continue the presentation (all participants) Presentation of certificates to all participants (Dr. Matsumoto, Mr. Shu & Ms. Chu) Closing ceremony (Mr. Brian Shu & Dr. Matsumoto) Take a group photo at the front entrance of headquarters, BSMI (all participants)
	12:10–13:30	<i>Lunch break at the restaurant How-Tsu-Do Fon-Wui-Guang near BSIM (host staffs)</i>
	14:00–17:30	Technical visit to the 7th Division of BSMI, No. 78, Sec. 5, Cheng-de Road, Shih-lin District, Taipei (Mr. Cheng-Chih Chang & host staffs) / Visit Taipei 101 (host staffs)

\*Persons in ( ) are the speakers or instructors.

## Participants List of Seminar on Automated Sphygmomanometers

July 17 – 21, 2006 at the Howard International House in Taipei, Chinese Taipei

No.	Category	Economy	Name	Organization
1	Speaker	Germany	Dr. Stephan Mieke	Head, Standards for Medical Metrology, Physikalisch-Technische Bundesanstalt (PTB)
2	Speaker	Japan	Mr. Shinichi Bunryou	Research Scientist, Pattern Approval Section, Dissemination Technology Division, National Metrology Institute of Japan, AIST
3	Speaker	Chinese Taipei	Mr. Chen-Chuan Hung	Researcher, Mechanical Measurement Laboratory, Measurement Standards & Technology Division, Center for Measurement Standards (CMS), Industrial Technology Research Institute (ITRI)
4	Speaker	Chinese Taipei	Dr. Chang-Chyi Lin	Cheng Hsin Rehabilitation Medical Center
5	APLMF	Japan	Dr. Tsuyoshi Matsumoto	National Metrology Institute of Japan, AIST
6	WG/Host	Chinese Taipei	Dr. Chi-Sheng Chang	Center for Measurement Standards (CMS), Industrial Technology Research Institute (ITRI)
7	WG/Host	Chinese Taipei	Mr. Cheng-Chih Chang	Bureau of Standards, Metrology and Inspection (BSMI), Ministry of Economic Affairs
8	WG/Host	Chinese Taipei	Mr. Shih-Ming Chang	Electronics Testing Center, Taiwan.
9	WG/Host	Chinese Taipei	Dr. Jay-San Chen	Bureau of Standards, Metrology and Inspection (BSMI), Ministry of Economic Affairs
10	WG/Host	Chinese Taipei	Mr. Wu-Hsiung Chen	Bureau of Standards, Metrology and Inspection (BSMI), Ministry of Economic Affairs
11	WG/Host	Chinese Taipei	Mr. Henry Cheng	Electronics Testing Center, Taiwan.
12	WG/Host	Chinese Taipei	Ms. Meggie Chu	Bureau of Standards, Metrology and Inspection (BSMI), Ministry of Economic Affairs
13	WG/Host	Chinese Taipei	Mr. Lai-Ho Huang	Bureau of Standards, Metrology and Inspection (BSMI), Ministry of Economic Affairs
14	WG/Host	Chinese Taipei	Ms. Yuh-Guang Jin	Bureau of Standards, Metrology and Inspection (BSMI), Ministry of Economic Affairs
15	WG/Host	Chinese Taipei	Mr. David Y. Wang	President, Electronics Testing Center, Taiwan.
16	WG/Host	Chinese Taipei	Mr. Jin-Hai Yang	Bureau of Standards, Metrology and Inspection (BSMI), Ministry of Economic Affairs
17	Trainee	Cambodia	Mr. Kim Chandara	Department of Metrology, Ministry of Industry, Mines and Energy
18	Trainee	Indonesia	Mr. Nino Wawan Setiawan	Directorate of Metrology, General Directorate of Domestic Trade, Ministry of Trade of Republic Indonesia
19	Trainee	Malaysia	Ms. Hairani Binti Nordin	National Metrology Laboratory, SIRIM Berhad (NML-SIRIM)
20	Trainee	Mongolia	Mr. Dashrenchin Bayasgalan	Mongolian Agency for standardization and Metrology
21	Trainee	Papua New Guinea	Mr. Reuben Koi Harokave	National Institute of Standards and Industrial Technology
22	Trainee	Peru	Mr. Leonardo De La Cruz	National Institute for the Defense of Competition and Protection of Intellectual Property
23	Trainee	Philippines	Mr. Radley Flores Manalo	National Metrology Laboratory, Industrial Technology Development Institute (ITDI)

24	Trainee	Viet Nam	Mr. Bui Trung Dung	Metrology Department, Directorate for Standards and Quality-STAMEQ
25	Trainee	Chinese Taipei	Mr. Chen Horng-Lin	Bureau of Standards, Metrology and Inspection (BSMI), Ministry of Economic Affairs
26	Trainee	Chinese Taipei	Ms. Jennifer Chu	Rossmax International Ltd.
27	Trainee	Chinese Taipei	Mr. Bo-Sen Fu	Electronics Testing Center, Taiwan.
28	Trainee	Chinese Taipei	Mr. Chen-Chuan Hung	Measurement Standards & Technology Division, CMS, ITRI
29	Trainee	Chinese Taipei	Mr. Fu-Chang Kung	Bureau of Standards, Metrology and Inspection (BSMI), Ministry of Economic Affairs
30	Trainee	Chinese Taipei	Mr. Alex Kou	HEALTH & LIFE CO. , LTD
31	Trainee	Chinese Taipei	Mr. Chen Cheng Kuo	Bureau of Standards, Metrology and Inspection (BSMI), Ministry of Economic Affairs
32	Trainee	Chinese Taipei	Mr. Ching-Chia Lai	Bureau of Standards, Metrology and Inspection (BSMI), Ministry of Economic Affairs
33	Trainee	Chinese Taipei	Mr. Alan Lee	Mars Metal Co. , Ltd.
34	Trainee	Chinese Taipei	Mr. Wen Lang Lin	Bureau of Standards, Metrology and Inspection (BSMI), Ministry of Economic Affairs
35	Trainee	Chinese Taipei	Mr. Chun Pin Liu	Bureau of Standards, Metrology and Inspection (BSMI), Ministry of Economic Affairs
36	Trainee	Chinese Taipei	Mr. Wen Pin Tsai	Bureau of Standards, Metrology and Inspection (BSMI), Ministry of Economic Affairs
37	Trainee	Chinese Taipei	Ms. Ariel Wang	Microlife Corporation
38	Trainee	Chinese Taipei	Ms. Sammi Chung	Bureau of Standards, Metrology and Inspection (BSMI), Ministry of Economic Affairs
39	Trainee	Chinese Taipei	Mr. Brian C.S. Shu	Bureau of Standards, Metrology and Inspection (BSMI), Ministry of Economic Affairs
40	Trainee	Chinese Taipei	Ms. Pei-Ping Wang	Bureau of Standards, Metrology and Inspection (BSMI), Ministry of Economic Affairs
41	Trainee	Chinese Taipei	Mr. Te-Shuen Wang	Bureau of Standards, Metrology and Inspection (BSMI), Ministry of Economic Affairs
42	Trainee	Chinese Taipei	Mr. Jenn-Chyi Yang	Bureau of Standards, Metrology and Inspection (BSMI), Ministry of Economic Affairs

\*Names are listed in alphabetical order of their categories, economies and last names.



## APEC/APLMF Training Courses in Legal Metrology (CTI-11/2006T)

### Seminar on Automated Sphygmomanometers

### OIML R 16-2 “Non-invasive Sphygmomanometer”

Stephan Mieke

Physikalisch-Technische Bundesanstalt  
Berlin

#### Overview:

- Medical background
- Techniques to measure indirectly the blood pressure
- Requirements, Standards etc. for sphygmomanometer
- Requirements for automated sphygmomanometer (pattern approval)
- Requirements for automated sphygmomanometer (verification)

#### Overview:

- Medical background
- Techniques to measure indirectly the blood pressure
- Requirements, Standards etc. for sphygmomanometer
- Requirements for automated sphygmomanometer (pattern approval)
- Requirements for automated sphygmomanometer (verification)

1896



Right: **Scipione Riva-Rocci** graduated in medicine and surgery in 1888 from the University of Torino with the medical doctorate.

Left: An early sphygmomanometer designed on Riva-Rocci's ideas.



1905

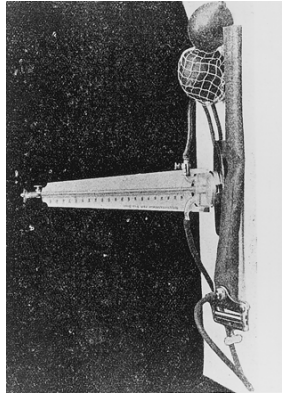

Right: **Nikolai Sergeevich Korotkoff** presented a report on a new method of measurement of arterial pressure on November 8, 1905, at a scientific seminar of the Imperial Military Medical Academy, Saint Petersburg, Russia.

Left: The Riva-Rocci sphygmomanometer he was using for his thesis (the stethoscope is not shown).

**The heart as a pump**

Man's biological functions are maintained by the circulation of the blood through the human body. This transport system performs many functions; for example, oxygen and nutrients are supplied to the cells and carbon dioxide and metabolic products carried away. The blood and its constituents have many other functions, e.g. the defence against exogenic substances penetrating the body.

The blood is constantly circulating through man's arterial and venous system. This flow of blood to all parts of the body is maintained by two pumps, the left side and the right side of the heart.

The left side of the heart pumps the blood oxygenated in the lungs into the arterial system, thus supplying blood to the muscles, organs and other cells. The blood passes from the lungs through the left auricle, the aorta and the arteries to ever smaller vessels which ultimately end at the cells in a large number of arterioles and capillaries.

In contrast to this, the right side of the heart pumps the blood, in which carbon dioxide has been absorbed, from the venous system into the lungs to make gaseous interchange possible. The blood in the numerous small veins takes up the metabolic products of the cells and carries these to the organs of excretion. Carbon dioxide is breathed out in the lungs. Through the venous system and the right side of the heart, the blood flows into the lungs.

The pumping of the left side of the heart leads to blood pressure fluctuations in the arterial system. The contraction of the cardiac muscle (systole) results in a strong expulsion of blood and a somewhat delayed pressure increase in the aorta. The pressure increase passes through a maximum while the expulsion of blood decreases again. During the relaxation phase of the heart muscle (diastole), the left heart valve closes. Although blood is no longer expelled, the blood pressure in the aorta does by no means drop to zero but continues to decrease slowly until it rises again as a result of the next systole. This effect is a consequence of the vessel's elasticity and peripheral resistance.

**Blood Circulation**  
Principal Veins and Arteries

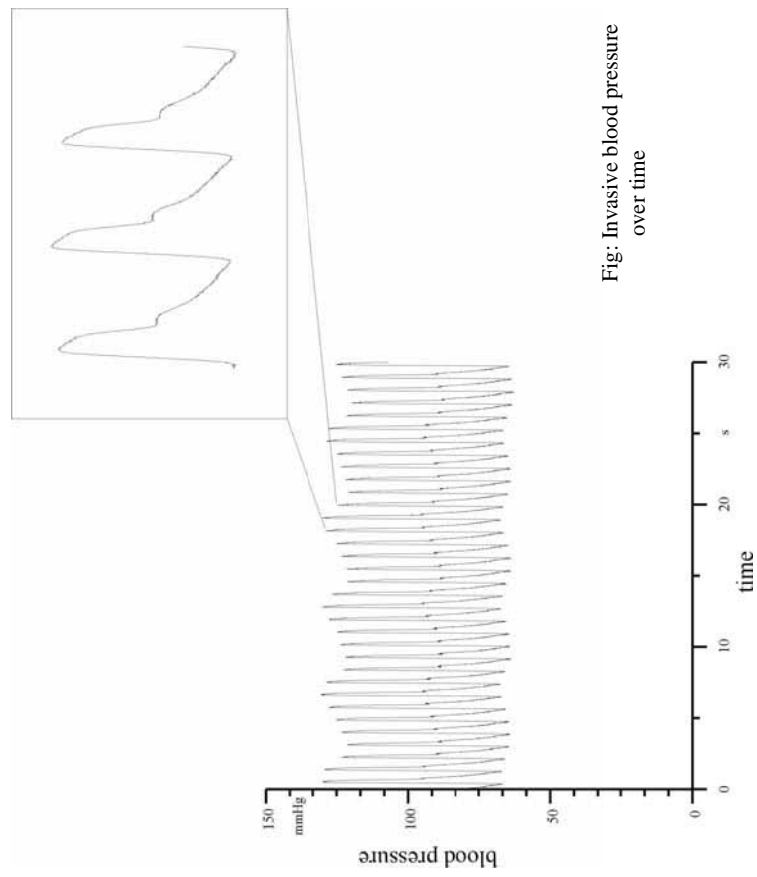
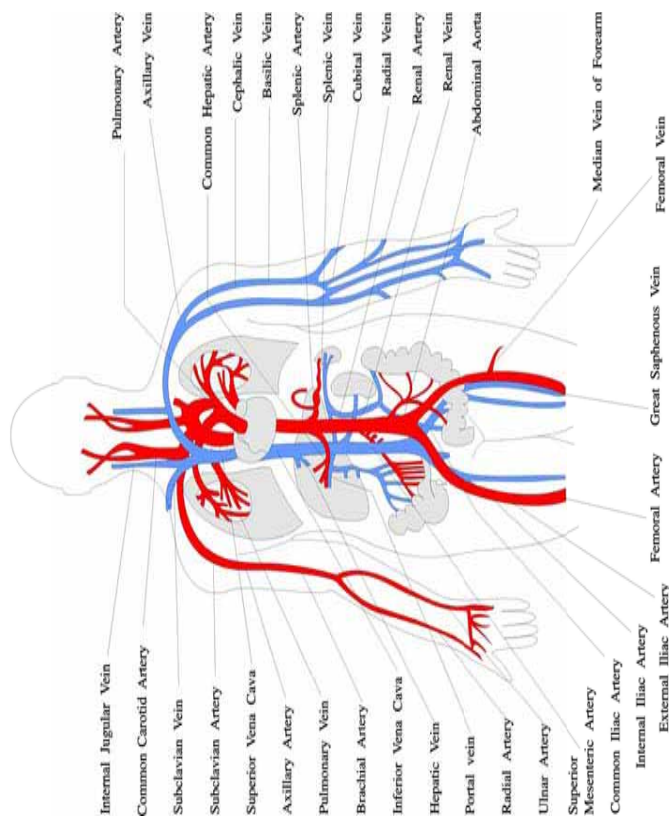

Fig: Invasive blood pressure over time



## Hypertension a global challenge

Recent analysis show that as of 2000 there are 972 million people living with hypertension worldwide and it is estimated that this number will escalate to more than 1.5 billion in 2025 (Kearney PM et al. Lobal burdon of hypertension: analysis of worldwide data. Lancet 2005; 265: 217-23).

World Hypertension League (WHL) - Newsletter, No. 107, June 2006, Editorial by Arun Chockalingam, Canada: Although measurement of blood pressure is a simple procedure it is not done properly by health care professionals all around the world. ... more than 50% of the hypertensive population are unaware of their condition; of those who are aware more than 50% have not been treated.

WHO Report: Reducing risks, promoting healthy life, Geneva 2002 (http://www.who.int/whr/2002/en):

Raised blood pressure is almost always without symptoms. However, elevated blood pressure levels produce a variety of structural changes in the arteries that supply blood to the brain, heart, kidneys and elsewhere. In recent decades it has become increasingly clear that the risks of stroke, ischaemic heart disease, renal failure and other disease ...

Globally, these analyses indicate that about 62% of cerebrovascular disease and 49% of ischaemic heart disease are attributable to suboptimal blood pressure (systolic >115 mmHg), with little variation by sex.

## Mean arterial pressure

An additional value is often stated, i.e. the mean arterial pressure (MAP), which can be determined by various methods. The definition is given by the integral of the blood pressure curve related to one heart beat. Since the continual determination of the blood pressure curve is possible only by invasive methods and by only few non-invasive methods, different approximation methods exist.

The approximation most frequently applied is as follows:

$$P_{MAP} = P_{dia} + 1/3 (P_{sys} - P_{dia})$$

$P_{MAP}$ : mean arterial pressure

Sphygmomanometers applying the oscillometric method usually indicate the oscillation maximum as mean arterial pressure.

## Classification of blood pressure values

On the basis of the blood pressure values, a distinction is made between men with low, normal and high blood pressure (hypotonic, normotonic, hypertonic):

Limiting values of the blood pressure in the state of rest

Hypotension:  $P_{sys} < 100$  mmHg,  $P_{dia} < 60$  mmHg

Hypertension:  $P_{sys} > 160$  mmHg,  $P_{dia} > 95$  mmHg

$P_{sys}$ : systolic blood pressure,  $P_{dia}$ : diastolic blood pressure

A. Blood pressure

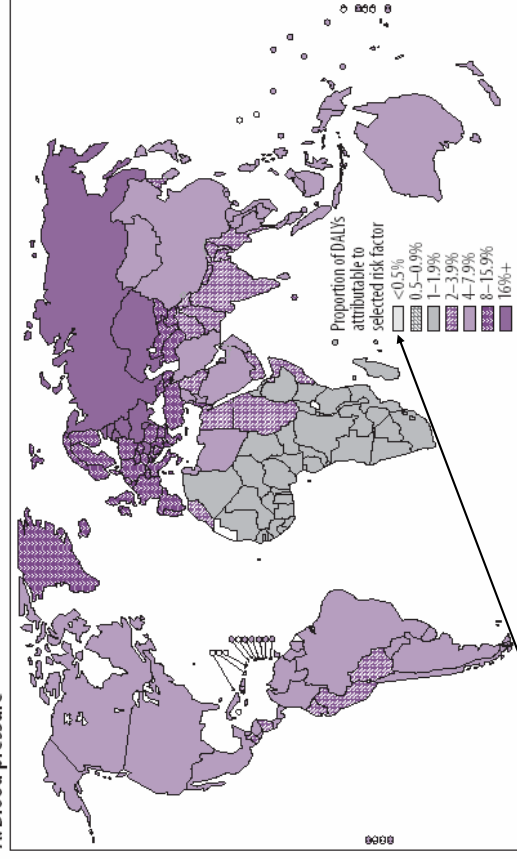

DALY (disability-adjusted life year) – one DALY being equal to the loss of one healthy life year

### Sites of blood pressure measurement

The upper part of the arm is normally used for non-invasive blood pressure measurement. There is only one larger artery in the upper arm, the arteria brachialis, which conveys blood to the lower arm and the hand.

The advantages of this place of measurement are as follows:

- the measurement is taken at not too great a distance from the heart,
- the influence of the periphery is not yet important,
- the measurement is taken at heart level (with the arm in normal position).

Another site of blood pressure measurement is the thigh. The disadvantages as compared with the upper arm are above all the greater distance from the heart and the necessity to take the measurement with the patient lying to avoid hydrostatic effects, i.e. to measure at heart level.

Especially for home-use devices the measurement at the wrist has become very popular in the past 10 years. This site can be used only by automated oscillometric devices. As for the thigh, it is necessary to avoid the hydrostatic effect (5 cm misplacement in height yield an error of ca. 4 mmHg). Clinical evaluations have shown, that most devices are less accurate, than upper arm devices.

### The Korotkoff method

The non-invasive method developed in 1905 by Nikolai Sergejevitch Korotkoff, a Russian doctor, uses a cuff and a stethoscope. The measurement is usually carried out on the upper arm, but measurement on the thigh is also feasible.

First the cuff on the upper arm is inflated to a pressure value higher than the expected systolic blood pressure, so that the blood stops flowing through the arteries beyond the cuff. The stethoscope is placed below the cuff, above the arteria brachialis. Air from the cuff is then slowly released by opening of the valve so that the cuff pressure drops slowly. While the pressure in the cuff is reduced, sounds can be heard with the stethoscope.

The sounds named after Korotkoff follow the rhythm of the heart beats. When the Korotkoff sounds are heard for the first time, the manometer is read and the value taken as systolic blood pressure value. With the cuff pressure falling, the sounds change in tone colour and ultimately fade out completely; at this moment the doctor reads the cuff pressure once again and takes it as diastolic blood pressure value.

Classification of the Korotkoff sounds into phases

- Phase I: The period marked by the first appearance of faint, clear trapping sounds which gradually increase in intensity.
- Phase II: The period during which a murmur or swishing quality is heard.
- Phase III: The period during which sounds are crisper and increase in intensity.
- Phase IV: The period marked by the distinct, abrupt muffling of sound so that a soft, blowing quality is heard.
- Phase V: The point at which sounds disappear.

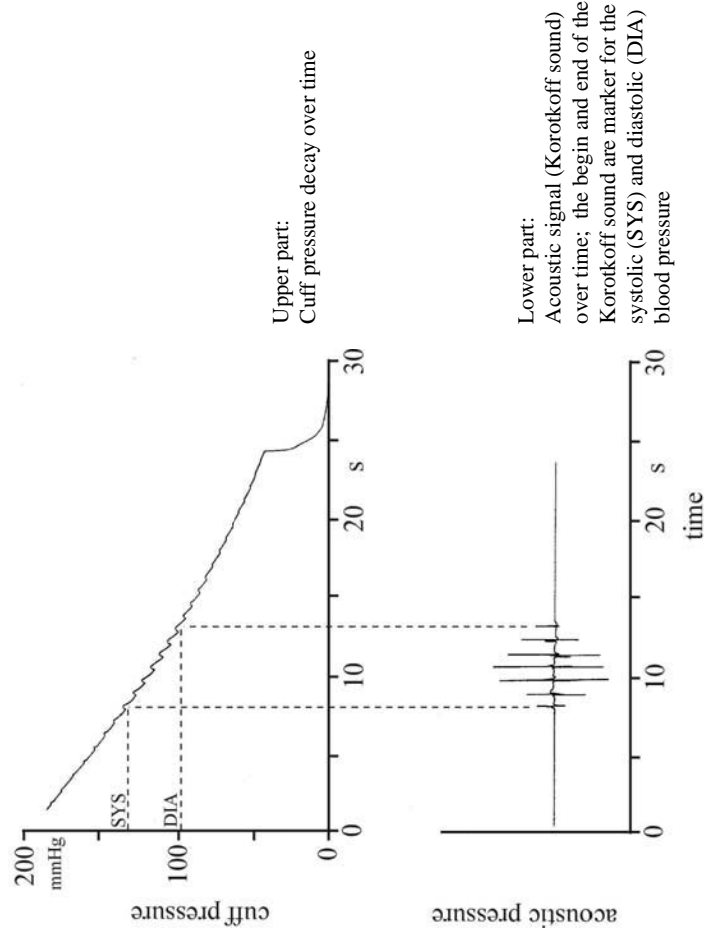

### Optimal deflation rate

The deflation rate is one of the most important factors for the accuracy of the Korotkoff method.

The determination of the systolic and diastolic blood pressure is based on the audible sounds. The first Korotkoff sound will be audible, when the blood pressure is just a little bit higher, than the cuff pressure affecting the artery. If the deflation rate is very high (> 3 mmHg/s) this first moment will be detected less accurate. The maximum error is directly proportional to the deflation rate.

As a consequence one would suggest very low deflation rates, minimizing this error, unfortunately it yields another problem. Low deflation rates (< 2 mmHg/s) result in a long lasting measurement and an increase of blood in the downer arm. The blood is 'trapped' in the downer arm because the venous pressure is too low (< 30 mmHg) to pass the cuff and to flow back to the right heart. Since this is an extraordinary physiological state the 'true' blood pressure in the arm is increasing, i.e. the blood pressure becomes different from the real one.

The same explanation applied for the determination of the diastolic pressure.

As a compromise deflation rates of 2-3 mmHg/s are suggested to get the best results.

## Cuff

The cuff consists of a fabric or synthetic sleeve enclosing a bladder. Disposable cuffs, especially those for newborn children (neonates) are often manufactured of welded synthetic material with integrated bladder.

Since the cuff pressure directly influences the blood flow through the arteria brachialis or other arteries - tissue, muscles and bones may be considered as almost incompressible - the ratio of upper arm circumference to cuff width is of decisive importance to the accuracy.

National organisations, mostly medical associations, have drawn up recommendations for suitable cuffs. The table shows the American recommendations.

Table: Cuff bladders recommended by the American Heart Association

patient	upper arm circumference (cm)	bladder of the cuff, width * length (cm * cm)
neonates	5 - 7,5	3 * 5
infant	7,5 - 13	5 * 8
child	13 - 20	8 * 13
small adult	17 - 26	11 * 17
adult	24 - 32	13 * 24
large adult	32 - 42	17 * 32
thigh	42 - 50	20 * 42

## Oscillometric method

At the end of the seventies, automated sphygmomanometers applying the oscillometric method were developed for the first time. They were able to determine the systolic and diastolic blood pressure values by means of mathematical algorithms. Similar to the Korotkoff method, the oscillometric method makes use of a cuff applied to the upper arm, however, no stethoscope is required. Additionally the measurement at the wrist is also possible. The oscillometric method can only be applied in electronic sphygmomanometers; manual measurement by the doctor with the aid of a manometer is not practicable.

The measurement procedure is as follows:

- First the cuff pressure is pumped to a value higher than the expected systolic blood pressure.
- Then the cuff pressure is deflated continuously or in steps.
- The pressure pulse in the arteria brachialis (at the wrist: a. radialis and a. ulnaris) is transferred via the bladder of the cuff to the pneumatic system of the instrument and results in small pressure fluctuations (oscillations). Small fluctuations of the cuff pressure can already be observed before the systolic blood pressure value is reached. These pressure fluctuations are the important measured values of the oscillometric method as their amplitude changes while the cuff pressure is reduced further.
- The paired values of the oscillation amplitudes and the corresponding cuff pressures are recorded during the measurement. These data are mathematically evaluated after the end of the measurement and the results, i.e. the blood pressure values, are displayed.

The mathematical procedures (algorithms) applied to determine the blood pressure values are often considered as secrets. With the exception of some details, the algorithm most frequently used is, however, generally known and will be discussed in the following:

After the cuff pressure was deflated from a value above the systolic blood pressure to a value below the diastolic blood pressure, the values of the oscillation amplitudes and of the respective cuff pressures are stored in the memory.

Fig. 2 and 3 show the pressure amplitudes in the form of vertical bars.

On the basis of extensive investigations, the following relations have been discovered:

1. The maximum of the oscillation amplitude  $A_{max}$  coincides with the mean arterial blood pressure, in short MAP.
2. The systolic blood pressure is determined at about  $0.5 A_{max}$ .
3. The diastolic blood pressure is determined at about  $0.8 A_{max}$ .

Note1:

Only the principle underlying the procedure most frequently applied has been described here; to improve its reliability, the method has been refined and extended in many aspects.

Note2:

The factors given above are those roughly valid for measurements at the upper arm. The factors for the wrist are totally different.

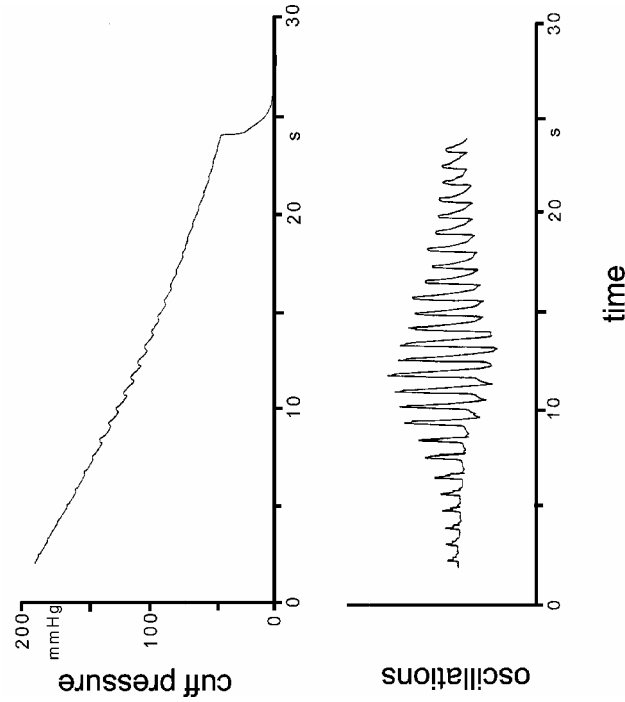

Fig. 1: Upper part: curve of deflating cuff pressure, lower part: amplitude of pressure oscillations

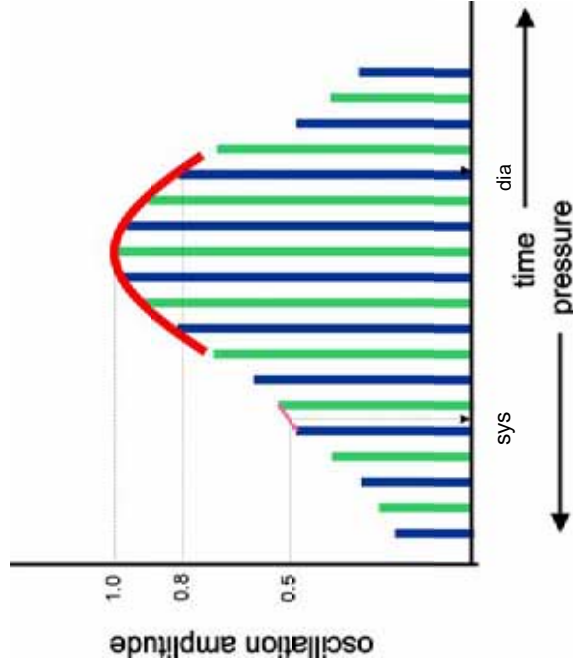

Fig. 2: Oscillometric principle

**Overview:**

- Medical background
- Techniques to measure indirectly the blood pressure
- Requirements, Standards etc. for sphygmomanometer
- Requirements for automated sphygmomanometer (pattern approval)
- Requirements for automated sphygmomanometer (verification)

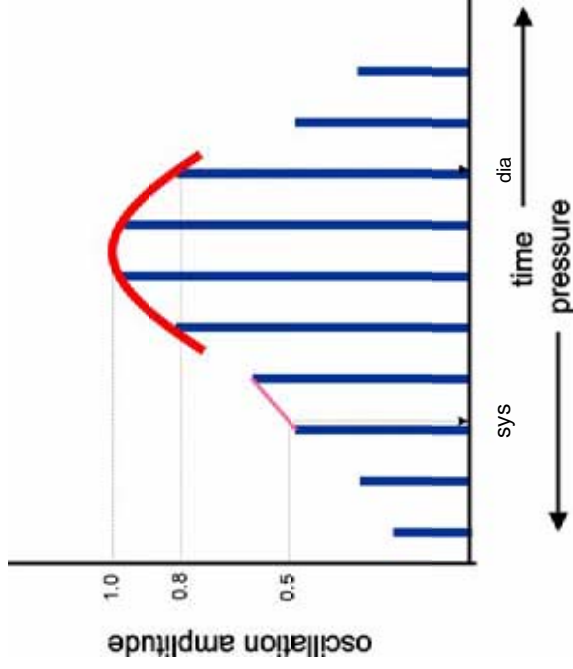

Fig. 3: Oscillometric principle

**OIML International Recommendation R16 (2002)**

- R 16-1 Non-invasive mechanical sphygmomanometers
- R 16-2 Non-invasive automated sphygmomanometers

**IEC 60601-2-30 (1999)**

Particular requirements for the safety, including essential performance, of automatic cycling non-invasive blood pressure monitoring equipment

**CEN EN 1060 (1995-1997-2004)**

- Part 1: General requirements
- Part 2: Supplementary requirements for mechanical sphygmomanometers
- Part 3: Supplementary requirements for electro-mechanical blood pressure measuring systems
- Part 4: Test procedures to determine the overall system accuracy of automated non-invasive sphygmomanometers

**ANSI/AAMI SP10 (2002)**

Manual, electronic, or automated sphygmomanometers

**OIML R16-2**  
**Non-invasive automated sphygmomanometers**

**1 Scope**

This Recommendation specifies general, performance, efficiency and mechanical and electrical safety requirements, including test methods for type approval, for non-invasive electronic or automated sphygmomanometers and their accessories which, by means of an inflatable cuff, are used for the non-invasive measurement of arterial blood pressure.

This Recommendation only applies to devices measuring at the upper arm, the wrist or the thigh.

*Note:* Luer locks shall not be used with these devices (see 6.1.1.3 and 7.5).

**7.1 Type approval**

At least three samples of a new type of sphygmomanometer shall be tested.

The tests to verify conformity to metrological and technical requirements shall be carried out according to Annex A. A test report shall be prepared according to Annex B.

**A.1 General**

For digital indications an uncertainty of 0.1 kPa (1 mmHg) shall be allowed in any displayed value, because the display system cannot indicate a change of less than one unit.

**A.2 Method of test for the maximum permissible errors of the cuff pressure indication**

Requirements in 5.1 shall apply.

**A.2.1 Apparatus**

- rigid metal vessel with a capacity of 500 ml  $\pm$  5 %;
- calibrated reference manometer with an uncertainty less than 0.1 kPa (0.8 mmHg);
- pressure generator, e.g. ball pump (hand pump) with a deflation valve;
- T-piece connectors and hoses.

**A.2.2 Procedure**

Replace the cuff with the vessel. Connect the calibrated reference manometer by means of a T-piece connector and hoses to the pneumatic circuit (see Figure 1). After disabling the electro-mechanical pump (if fitted), connect the additional pressure generator into the pressure system by means of another T-piece connector.

Carry out the test in pressure steps of not more than 7 kPa (50 mmHg) between 0 kPa (0 mmHg) and the maximum pressure of the scale range.\*

\*In case of doubt about the linearity, spot checks should be carried out or the width of the pressure steps should be reduced, i.e., from the normally recommended 7 kPa (50 mmHg) to 3 kPa (20 mmHg). This also applies to Table 1 in Annex B.

**A.2.3 Expression of results**

Express the results as the differences between the indicated pressure of the manometer of the device to be tested and the corresponding readings of the reference manometer (see B.2).

**Overview:**

- Medical background
- Techniques to measure indirectly the blood pressure
- Requirements, Standards etc. for sphygmomanometer
- Requirements for automated sphygmomanometer (pattern approval)
- Requirements for automated sphygmomanometer (verification)

**4 Units of measurement**

The blood pressure shall be indicated either in kilopascals (kPa) or in millimeters of mercury (mmHg).

**5 Metrological requirements**

**5.1 Maximum permissible errors of the cuff pressure indication**

For any set of conditions within the ambient temperature range of 15 °C to 25 °C and the relative humidity range of 20 % to 85 %, both for increasing and for decreasing pressure, the maximum permissible error for the measurement of the cuff pressure at any point of the scale range shall be  $\pm$  0.4 kPa ( $\pm$  3 mmHg) in case of verifying the first time and  $\pm$  0.5 kPa ( $\pm$  4 mmHg) for sphygmomanometers in use.

Testing shall be carried out in accordance with A.2.

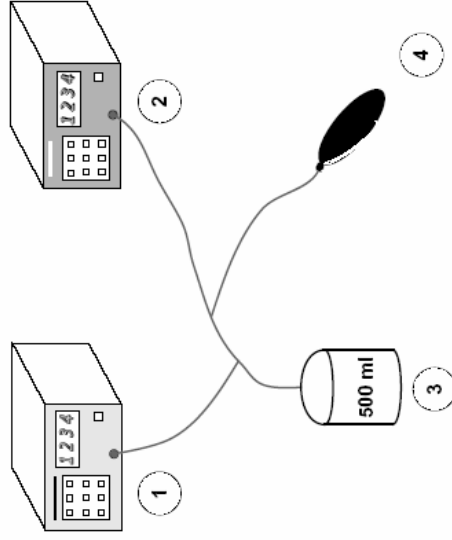

- 1 - Reference manometer
- 2 - Device to be tested
- 3 - Metal vessel
- 4 - Pressure generator

**Figure 1** Measurement system for determining the limits of error of the cuff pressure indication



**Figure:** Measurement setup to determine the limits of error of the cuff pressure indication (aneroid manometer)



**Figure:** Measurement setup to determine the limits of error of the cuff pressure indication (home use device)

### 5.2 Maximum permissible errors of the overall system as measured by clinical tests\* (\* carried out by the manufacturer)

The following maximum permissible errors shall apply for the overall system:

- maximum mean error of measurement:  $\pm 0.7$  kPa ( $\pm 5$  mmHg);
- maximum experimental standard deviation: 1.1 kPa (8 mmHg).

For further recommended test methods see Annex C.

## Annex C Rationale for the maximum permissible errors of the overall system (Informative)

- Note: This Annex provides a rationale for the values of maximum permissible errors presented in 5.2.
- Overall system accuracy**  
A clinical investigation is strongly recommended to demonstrate compliance with the requirements specified in 5.2.
- A new clinical investigation would be necessary only for changes affecting the overall system accuracy. Recommended protocols for the clinical investigations are given in:
- C.1 O'Brien E., Petrie J., Littler W., de Swiet M., Padfield P.L., Altman D.G., Bland M., Coats A. and Atkins N. The British Hypertension Society protocol for the evaluation of blood measuring devices. Journal of Hypertension 1993, 11 (Suppl 2): S 43 - 62
- ~~C.2 E.DIN.58130-1995. Non-invasive sphygmomanometers. - Clinical investigation.~~
- C.3 AAMI/ANSI SP10, American National Standard for electronic or automated sphygmomanometers, 1992, and Amendment, 1996
- Substituted by: EN 1060-4 Non-invasive sphygmomanometers - Test procedures to determine the overall system accuracy of automated non-invasive sphygmomanometers

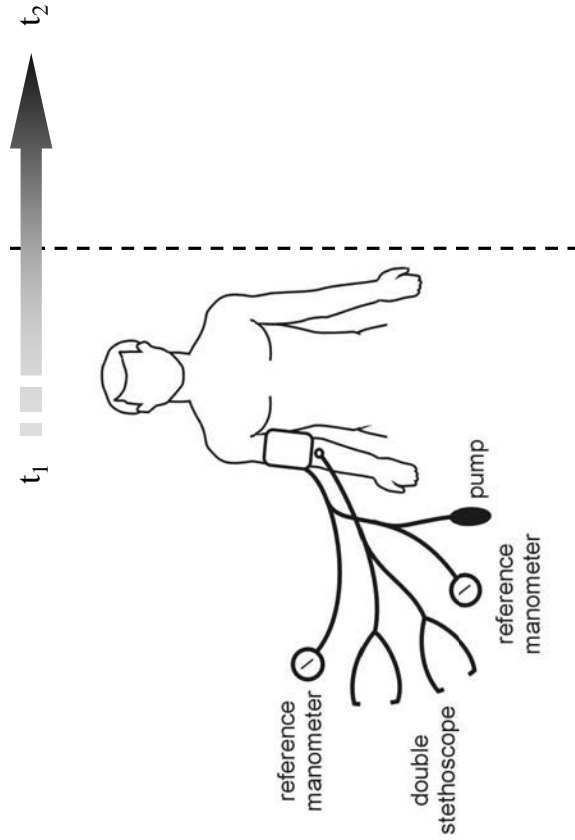

Fig.: Clinical test set-up according EN 1060-4 for devices with deflation rates higher than 3 mmHg/s (sequential measurement).

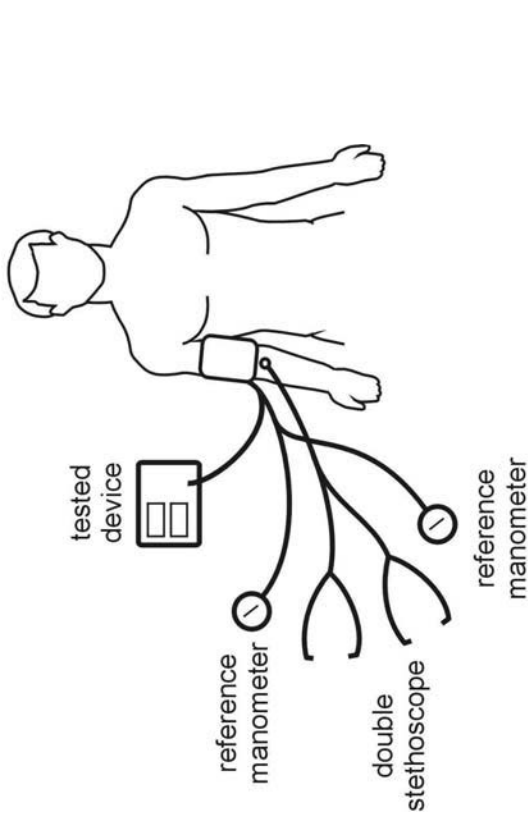

Fig: Clinical test set-up according EN 1060-4 for devices with deflation rates up to 3 mmHg/s.

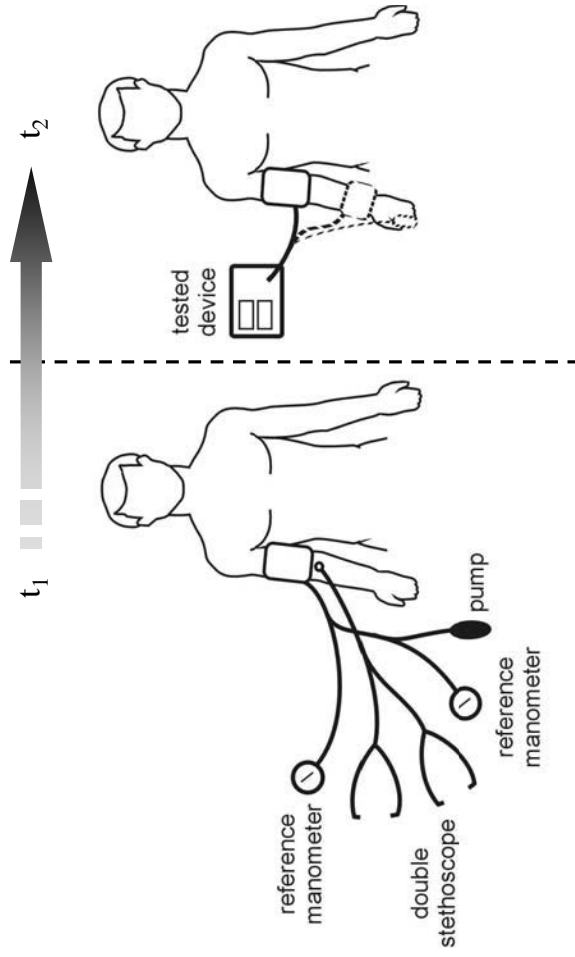

Fig.: Clinical test set-up according EN 1060-4 for devices with deflation rates higher than 3 mmHg/s (sequential measurement).

**5.3 Environmental performance**

**5.3.1 Storage**

Blood pressure measuring systems shall maintain the requirements specified in this Recommendation after storage for 24 h at a temperature of - 5 °C and for 24 h at a temperature of 50 °C and a relative humidity of 85 % (non-condensing).

Testing shall be carried out at environmental conditions (see 5.1) in accordance with A.2 after the test sample has been placed for 24 h at a temperature of - 5 °C and immediately afterwards for 24 h at a temperature of 50 °C in a climatic chamber.

*Note:* Integrated multiparameter monitors may contain components which may be damaged during storage.

The general temperature range as stated in A.3 has therefore been reduced compared to the requirements in R 16-1.

**A.2 Method of test for the maximum permissible errors of the cuff pressure indication**

.....

**5.3.2 Temperature, relative humidity**

For the ambient temperature range of 10 °C to 40 °C and a relative humidity of 85 % (non-condensing), the difference of the cuff pressure indication of the sphygmomanometer shall not exceed  $\pm 0.4$  kPa ( $\neq 3$  mmHg).

Testing shall be carried out in accordance with A.2 and A.11.

The signal processing for the determination of the blood pressure values shall not be influenced within the range of temperature and relative humidity. For any set of conditions all the deviations between the reference pressure and the indicating cuff pressure of the instrument must be less than or equal to the maximum permissible error.

**5.3.2 Temperature, relative humidity**

For the ambient temperature range of 10 °C to 40 °C and a relative humidity of 85 % (non-condensing), the difference of the cuff pressure indication of the sphygmomanometer shall not exceed  $\pm 0.4$  kPa ( $\neq 3$  mmHg).

Testing shall be carried out in accordance with A.2 and A.11.

The signal processing for the determination of the blood pressure values shall not be influenced within the range of temperature and relative humidity. For any set of conditions all the deviations between the reference pressure and the indicating cuff pressure of the instrument must be less than or equal to the maximum permissible error.

**A.2 Method of test for the maximum permissible errors of the cuff pressure indication**

.....

**A.11 Test method for the stability of the blood pressure determination (influence of temperature and humidity)**

**A.11.1 Apparatus**

- patient simulator as described in A.5.1.1;
- climatic chamber, capable of adjustment to an accuracy of 1 °C for the temperature and 5 % for the relative humidity.

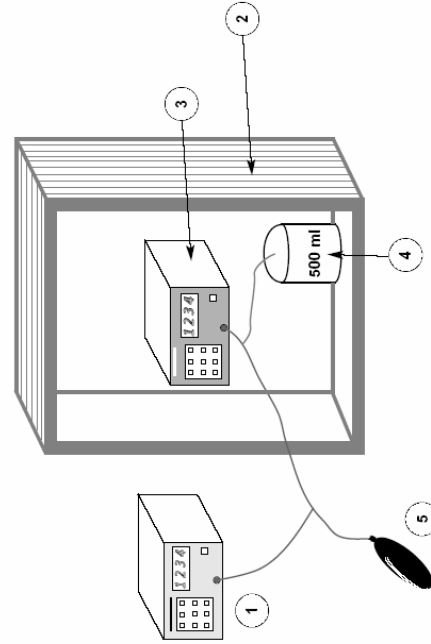

- 1 - Reference manometer
- 2 - Climatic chamber
- 3 - Device to be tested
- 4 - Metal vessel
- 5 - Pressure generator

**Figure:** Measurement system for determining the influence of temperature



### A.11.2 Procedure

Carry out the testing of the signal processing by means of the patient simulator. For each of the following combinations of temperature and humidity, place the blood pressure measuring system for at least 3 h in the climatic chamber to allow the system to reach steady conditions:

- 10 °C ambient temperature, 85 % relative humidity (non-condensing);
- 20 °C ambient temperature, 85 % relative humidity (non-condensing);
- 40 °C ambient temperature, 85 % relative humidity (non-condensing).

For each combination of temperature and humidity, take 20 consecutive readings of the blood pressure measuring system under test.

Place the blood pressure measuring system in the climatic chamber for at least 3 h. At each combination of temperature and humidity switch on the blood pressure measuring system before starting the test.

Wait until the warm up time (described in the instructions for use) has elapsed, carry out the measurement (20 consecutive readings) and switch off the blood pressure measuring system afterwards.

### A.11.3 Expression of results

Determine the mean value (systolic and diastolic values separately) of the 20 consecutive readings taken at each combination of temperature and humidity.

*Note:* Because the testing of the influence of temperature and humidity for the signal processing cannot be separated from the temperature/humidity effect on the pressure transducer and the deviations originating from the simulator, both contributions should be taken into account for the evaluation of the test.

## 6 Technical requirements

### 6.1 General

Equipment, or parts thereof, using materials or having forms of construction different from those detailed in this Recommendation shall be accepted if it can be demonstrated that an equivalent degree of safety and performance is obtained.

### 6.2 Technical requirements for the cuff and bladder

The cuff shall contain a bladder. For reusable cuffs the manufacturer shall indicate the method for cleaning in the accompanying documents (see 7.5).

*Note:* The optimum bladder size is one with dimensions such that its width is 40 % of the limb circumference at the midpoint of the cuff application and its length is at least 80 %, preferably 100 % of the limb circumference at the midpoint of cuff application. Use of the wrong size can affect the accuracy of the measurement.

### 6.3 Technical requirements for the display

The display shall be designed and arranged so that the information including measuring values can be read and easily recognized.

Testing shall be carried out by visual inspection.

If abbreviations are used on the display they shall be as follows:

- “S” or “SYS”: systolic blood pressure (value);
- “D” or “DJA”: diastolic blood pressure (value);
- “M” or “MAP”: mean arterial blood pressure (value).

Single letter abbreviations shall be positioned in such a way to avoid confusion with SI units.



**Figure: Measurement setup to determine the stability of the blood pressure determination;  
left: simulator, right open climatic chamber with automated sphygmomanometer**

### 6.4 Effect of voltage variations of the power source

#### 6.4.1 Internal electrical power source

6.4.1.1 Changes of the voltage within the working range determined according to A.4.1 shall not influence the cuff pressure reading and the result of the blood pressure measurement.

6.4.1.2 Outside this working range no cuff pressure reading and no result of the blood pressure measurement shall be displayed.

#### 6.4.2 External electrical power source

6.4.2.1 Changes of the voltage within the working range specified by the manufacturer (see 7.5) shall not influence the cuff pressure reading and the result of the blood pressure measurement.

6.4.2.2 Incorrect values resulting from voltage variations outside the limits given in 6.4.2.1 shall not be displayed.

*Note:* In the case of any malfunction of the equipment, deflation to below 2 kPa (15 mmHg) must be guaranteed within 180 s in the case of adult patients and to below 0.7 kPa (5 mmHg) within 90 s in the case of neonatal/infant patients.

## 6.5 Pneumatic system

### 6.5.1 Air leakage

Air leakage shall not exceed a pressure drop of 0.8 kPa/min (6 mmHg/min). Testing shall be carried out in accordance with A.6.

### 6.5.2 Pressure reducing system for devices using the auscultatory method

The pressure reducing system for manually operated and automated deflation valves shall be capable of maintaining a deflation rate of 0.3 kPa/s to 0.4 kPa/s (2 mmHg/s to 3 mmHg/s) within the target range of systolic and diastolic blood pressure. For devices which control the pressure reduction as a function of the pulse rate, a deflation rate of 0.3 kPa/pulse to 0.4 kPa/pulse (2 mmHg/pulse to 3 mmHg/pulse) shall be maintained.

*Note:* Manually operated deflation valves should be easily adjustable to these values.

Testing shall be carried out in accordance with A.7.



**Figure: Air leakage test set-up**

## A.7 Method of test for the pressure reduction rate

### A.7.1 Apparatus

- T-piece connectors;
- calibrated reference manometer with signal output port and an uncertainty less than 0.1 kPa (0.8mmHg);
- artificial or human limbs (see *Notes* under A.7.2);
- recording unit.

### A.7.2 Procedure

Measure the pressure reduction rate either on human subjects or artificial limbs.

*Note 1:* The intention is to use artificial limbs, but as these are still under consideration, measurements performed with human volunteers are acceptable.

*Note 2:* Two limb sizes should be used, being equal to the upper and lower limits of limb circumferences with which a particular size of cuff is recommended for use.

*Note 3:* It is intended that the characteristics of the artificial limbs reflect some elastic characteristics of human limbs.

Because the cuff deflation rate may be influenced by the way that a cuff is applied, apply and remove the cuff for each of at least ten repeated measurements on at least two different limb sizes. The deflation may be reset. Connect the calibrated reference manometer to the cuff by means of a T-piece. Connect the output part of the calibrated reference manometer to the recording unit.

### A.7.3 Expression of results

Determine the rate of pressure reduction (e.g. by graphical evaluation and drawing tangents) at the pressure values 8 kPa (60 mmHg), 16 kPa (120 mmHg) and 24 kPa (180 mmHg). Calculate the pressure reduction rate as the mean value calculated separately for the pressure values 8 kPa (60 mmHg), 16 kPa (120 mmHg) and 24 kPa (180 mmHg) and for the various limb circumferences. If the pressure reduction rates are dependent on the pulse, record the pulse rate. In this case, express the result as pressure reduction rate per pulse.

### 6.5.3 Rapid exhaust

During the rapid exhaust of the pneumatic system, with the valve fully opened, the time for the pressure reduction from 35 kPa to 2 kPa (260 mmHg to 15 mmHg) shall not exceed 10 s.

For blood pressure measuring systems having the capability to measure in a neonatal/infant mode, the time for the pressure reduction from 20 kPa to 0.7 kPa (150 mmHg to 5 mmHg) during the rapid exhaust of the pneumatic system with the valve fully opened shall not exceed 5 s.

Testing shall be carried out in accordance with A8.

### A.8 Method of test for the rapid exhaust valve

#### A.8.1 Apparatus

- two rigid vessels with capacities of 100 ml  $\pm$  5 % and 500 ml  $\pm$  5 %, respectively;
- calibrated reference manometer with an uncertainty less than 0.1 kPa (0.8 mmHg);
- T-piece connector;
- stopwatch.

#### A.8.2 Procedure

Carry out the test with the 500 ml vessel in place of the cuff. For blood pressure measuring systems having the capability of measuring in a neonatal/infant mode and for devices measuring at the wrist, carry out the test with the 100 ml vessel in place of the cuff. Connect the calibrated reference manometer by means of a T-piece to the pneumatic system. Inflate at least to the maximum pressure given in 6.5.3. **wait 60 s** and activate the rapid exhaust valve. Measure the time between the pressure values specified in 6.5.3 using the stopwatch.

#### A.8.3 Expression of results

Express the results as the measured exhaust times.

### A.9 Test method for the zero setting

#### A.9.1 Apparatus

- rigid vessel with a capacity of 500 ml  $\pm$  5 %;
- calibrated reference manometer with an uncertainty less than 0.1 kPa (0.8 mmHg);
- electro-mechanical pressure/suction pump;
- pressure generator, e.g. ball pump (hand pump) with deflation valve;
- T-piece connectors;
- hoses.

#### A.9.2 Procedure and evaluation

If, because of technical reasons, the test as described in this subclause cannot be performed, use an alternative test procedure specified by the manufacturer. To test the function of the zero setting, apply a pressure of + 0.8 kPa (+ 6 mmHg) and subsequently - 0.8 kPa (- 6 mmHg) to the pneumatic system and initiate a zero setting of the device. Ensure that all displayed pressure values have a systematic error of - 0.8 kPa (- 6 mmHg) and + 0.8 kPa (+ 6 mmHg), respectively. Before beginning the test, allow the blood pressure measuring system to reach working temperature.

Set up the blood pressure measuring system to be tested as follows:

- replace the cuff with the 500 ml vessel;
- insert the calibrated reference manometer into the pneumatic system by means of a T-piece connector;
- insert the pressure/suction pump into the pneumatic system by means of a T-piece connector;
- insert the pressure generator into the pneumatic system by means of a T-piece connector.

*Note:* If convenient, one adjustable pump may be used in place of the pressure/suction pump and pressure generator to generate the pressures.

### 6.5.4 Zero setting

Blood pressure measuring systems shall be capable of automatic zero setting. The zero setting shall be carried out at appropriate intervals, at least starting after switching on the device.

At the moment of the zero setting a gauge pressure of 0 kPa (0 mmHg) shall exist and be displayed thereafter.

Devices performing zero setting only immediately after switching on, shall switch off automatically when the drift of the pressure transducer and the analog signal processing exceeds 0.1 kPa (1 mmHg).

Testing shall be carried out in accordance with A.9 and A.10.

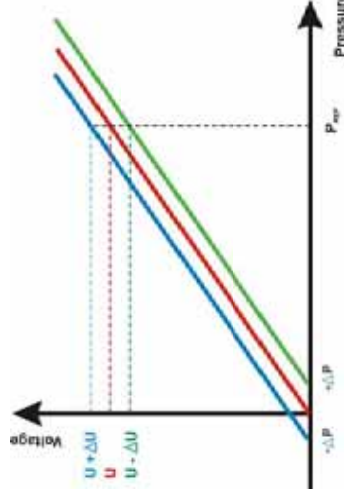

Figure: Applying positive or negative pressure at the moment of zero setting will result in a decrease or increase of voltage (or displayed pressure), thus proving that the zero setting software works correctly.

Proceed in the following way:

- Initiate a zero setting as described by the manufacturer. Set the blood pressure measuring system to the service mode, if available. Raise the pressure to 13 kPa (100 mmHg) immediately afterwards and record the displayed value.
- Generate a constant gauge pressure of + 0.8 kPa (+ 6 mmHg) in the pneumatic system by using the pressure/suction pump at the moment of zero setting. During this period close the deflation valve of the device under test or close the hose to it, e.g. by pinching the hose tightly. Set the blood pressure measuring system to the service mode, if available. Raise the pressure to 13 kPa (100 mmHg) immediately afterwards. The zero setting is operating correctly if the displayed value decreases by 0.8 kPa (6 mmHg) compared to the value taken in a).
- Repeat b) with a constant gauge pressure of - 0.8 kPa (- 6 mmHg) in the pneumatic system. Set the blood pressure measuring system to the service mode, if available. Raise the pressure to 13 kPa (100 mmHg) immediately afterwards. The zero setting is operating correctly if the displayed value increases by 0.8 kPa (6 mmHg) compared to the value taken in a).

## A.10 Test method for the drift of the cuff pressure indication

### A.10.1 General

This test applies for devices performing zero setting only immediately after switching on.

### A.10.2 Apparatus

- rigid vessel with a capacity of 500 ml  $\pm$  5 %;
- calibrated reference manometer with an uncertainty less than 0.1 kPa (0.8 mmHg);
- stopwatch;
- T-piece connectors;
- patient simulator as described in A.5.1.1.

### A.10.3 Procedure and evaluation

Replace the cuff with the 500 ml vessel. Insert the calibrated reference manometer and the patient simulator into the pneumatic circuit by means of T-piece connectors.

Before beginning the test, allow the blood pressure measuring system to reach operating temperature as described in the instructions for use. Test the stability of the cuff pressure indication after the zero setting at a pressure value of 7 kPa (50 mmHg) according to the procedure specified in A.2. Under the same environmental conditions determine the time (t1) until the change of the cuff pressure indication exceeds 0.1 kPa (1 mmHg). Switch off the device and switch on afterwards. Perform one blood pressure measurement and wait until the device has switched off automatically. Determine the time (t2) between switching on and automatically switching off. The time (t2) shall be less than or equal to the time (t1).

### 6.7 Stability of the cuff pressure indication

The change in the cuff pressure indication shall not be more than 0.4 kPa (3 mmHg) throughout the pressure range after 10 000 simulated measurement cycles.

Testing shall be carried out in accordance with A.12.

## A.12 Test method for the stability of cuff pressure indication following prolonged usage

### A.12.1 Procedure

Carry out the test according to the procedure specified in A.2 prior to prolonged usage.

Perform 10 000 simulated measurement cycles with the complete blood pressure measurement system at which at least the following cuff pressure values shall be reached:

- adult mode: 20 kPa (150 mmHg);
- neonatal/infant mode: 10 kPa (75 mmHg).

*Note 1:* For devices which measure with the auscultatory and oscillometric method this test should be carried out for both modes.

*Note 2:* For devices which measure in both modes (adult and neonatal/infant) the test should be carried out in both modes.

### A.12.2 Expression of results

Express the result as the difference between the cuff pressure indication before and after 10 000 simulated blood pressure measurement cycles at the same test pressure and under the same environmental conditions.

## 6.6 Electromagnetic compatibility

Either:

- electrical and/or electromagnetic interferences shall not lead to degradations in the cuff pressure indication or in the result of the blood pressure measurement; or
- if electrical and/or electromagnetic interferences lead to an abnormality, the abnormality shall be clearly indicated and it shall be possible to restore normal operation within 30 s after cessation of the electromagnetic disturbance.

Testing should be carried out in accordance with the relevant OIML provisions (notably those of OIML D 11).

## 6.8 Pressure indicating device

### 6.8.1 Nominal range and measuring range

The nominal range for the cuff pressure measurement shall be specified by the manufacturer. The measuring and indication ranges of the cuff pressure shall be equal to the nominal range. Values of blood pressure measurement results outside the nominal range of cuff pressure shall be clearly indicated as out of range.

Testing shall be carried out by visual inspection.

**Definition** (International vocabulary of basic and general terms in metrology; IEC, ISO, OIML, ...):

*nominal range:* range of indication obtainable with a particular settings of the controls of a measuring instrument

*measuring range:* set of values of measurands for which the error of a measuring instrument is intended to lie within specified limits

### 6.8.2 Digital indication

The digital scale interval shall be 0.1 kPa (1 mmHg). If the measured value of a parameter is to be indicated on more than one display, all the displays shall indicate the same numerical value.

Measured numerical values on the display(s), and the symbols defining the units of measurement shall be arranged in such a way so as to avoid misinterpretation. Numbers and characters should be clearly legible.

Testing shall be carried out by visual inspection.

## 6.11 Safety

### 6.11.1 Cuff pressure

It shall be possible to abort any blood pressure measurement at any time by single key operation and this shall lead to a rapid exhaust (see 6.5.3).

Testing shall be carried out in accordance with A.14.

### A.14 Test method for the cuff pressure deflation following an aborted measurement

#### A.14.1 Apparatus

- calibrated reference manometer with an uncertainty less than 0.1 kPa (0.8 mmHg);
- T-piece connectors.

#### A.14.2 Procedure and evaluation

Insert the calibrated reference manometer into the pneumatic system by means of a T-piece. Start a blood pressure measurement. Abort the measurement during inflation. Start another measurement and abort it during the pressure reduction. If interval measurements are possible repeat the test in this mode. Check by visual inspection whether the rapid exhaust (6.5.3) is activated.

## 6.9 Signal input and output ports

The construction of the signal input and output ports (excluding internal interfaces, e.g. microphone signal input) relevant to the non-invasive blood pressure measurement shall ensure that incorrectly fitted or defective accessories shall not result in erroneous indication of cuff pressure or erroneous indication of blood pressure.

Testing shall be carried out in accordance with A.13.

## 6.10 Alarms

If alarms are used they shall be of at least medium priority.

### 6.11.2 Unauthorized access

All controls which affect accuracy shall be sealed against unauthorized access.

Testing shall be carried out by visual inspection.

### 6.11.3 Tubing connectors

Users of equipment intended for use in environments employing intravascular fluid systems shall take all necessary precautions to avoid connecting the output of the blood pressure measuring device to such systems as air might inadvertently be pumped into a blood vessel if, for example, Luer locks were used.

### 6.11.4 Electrical safety

Electronic or automated sphygmomanometers shall comply with the relevant national safety regulations.

### 6.11.5 Resistance to vibration and shock

The sphygmomanometer shall comply with the relevant provisions of OIML D 11 (e.g. subclause A.2.2 of the 1994 edition, *Mechanical conditions*). After testing, the device shall comply with the requirements of 5.1 (of this Recommendation).



## APEC/APLMF Training Courses in Legal Metrology (CTI-11/2006T)

### Seminar on Automated Sphygmomanometers

#### OIML R 16-2 “Non-invasive Sphygmomanometer”

Stephan Mieke  
Physikalisch-Technische Bundesanstalt  
Berlin

#### Overview:

- Medical background
- Techniques to measure indirectly the blood pressure
- Requirements, Standards etc. for sphygmomanometer
- Requirements for automated sphygmomanometer (pattern approval)
- Requirements for automated sphygmomanometer (verification)

#### 7.2 Verification

##### 7.2.1 Initial verification

At initial verification the requirements of 5.1 (Max. permissible error of the cuff pressure indication) and 6.5.1 (Air leakage)) shall be fulfilled.

Testing shall be carried out according to A.2 and A.6.

##### 7.2.2 Subsequent verification

Each instrument of an approved type of sphygmomanometer shall be verified every 2 years or after repair. At least 5.1 and 6.5.1 shall be fulfilled and tests must be carried out according to A.2 and A.6.

##### 7.3 Sealing

7.3.1 Control marks will be put on lead seals for which corresponding punched screws shall be attached whenever necessary. These seals shall prevent, without destruction of the control marks:

- in the case of patient-monitors in which the sphygmomanometer is one part of a system: the manipulation of the metrologically relevant parts for measuring blood pressure;
- in the case of all other manometers: the opening of the casing.

7.3.2 If the construction of the instrument guarantees security against any interference, the metrological control marks or the security marks may be attached in the form of labels.

7.3.3 All seals shall be accessible without using a tool.

#### 4 Units of measurement

The blood pressure shall be indicated either in kilopascals (kPa) or in millimeters of mercury (mmHg).

#### 5 Metrological requirements

##### 5.1 Maximum permissible errors of the cuff pressure indication

For any set of conditions within the ambient temperature range of 15 °C to 25 °C and the relative humidity range of 20 % to 85 %, both for increasing and for decreasing pressure, the maximum permissible error for the measurement of the cuff pressure at any point of the scale range shall be  $\pm 0.4$  kPa ( $\pm 3$  mmHg) in case of verifying the first time and  $\pm 0.5$  kPa ( $\pm 4$  mmHg) for sphygmomanometers in use.

Testing shall be carried out in accordance with A.2.

### A.1 General

For digital indications an uncertainty of 0.1 kPa (1 mmHg) shall be allowed in any displayed value, because the display system cannot indicate a change of less than one unit.

### A.2 Method of test for the maximum permissible errors of the cuff pressure indication

Requirements in 5.1 shall apply.

#### A.2.1 Apparatus

- rigid metal vessel with a capacity of 500 ml  $\pm$  5 %;
- calibrated reference manometer with an uncertainty less than 0.1 kPa (0.8 mmHg);
- pressure generator, e.g. ball pump (hand pump) with a deflation valve;
- T-piece connectors and hoses.

#### A.2.2 Procedure

Replace the cuff with the vessel. Connect the calibrated reference manometer by means of a T-piece connector and hoses to the pneumatic circuit (see Figure 1). After disabling the electro-mechanical pump (if fitted), connect the additional pressure generator into the pressure system by means of another T-piece connector. Carry out the test in pressure steps of not more than 7 kPa (50 mmHg) between 0 kPa (0 mmHg) and the maximum pressure of the scale range.\*

\*In case of doubt about the linearity, spot checks should be carried out or the width of the pressure steps should be reduced, i.e., from the normally recommended 7 kPa (50 mmHg) to 3 kPa (20 mmHg). This also applies to Table 1 in Annex B.

#### A.2.3 Expression of results

Express the results as the differences between the indicated pressure of the manometer of the device to be tested and the corresponding readings of the reference manometer (see B.2).

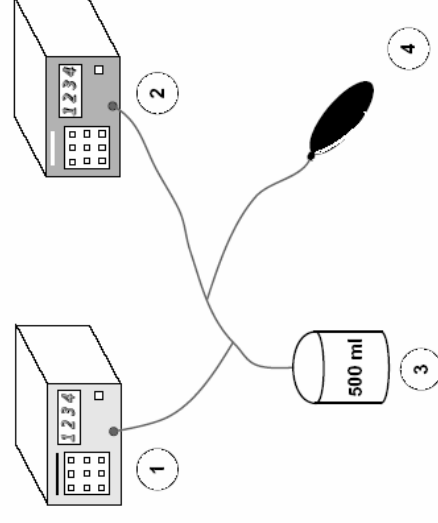

- 1 - Reference manometer
- 2 - Device to be tested
- 3 - Metal vessel
- 4 - Pressure generator

**Figure 1** Measurement system for determining the limits of error of the cuff pressure indication



**Figure:** Measurement setup to determine the limits of error of the cuff pressure indication (home use device, please note: the pressure is displayed in the systolic and diastolic field)

### Overview:

- Medical background
- Techniques to measure indirectly the blood pressure
- Requirements, Standards etc. for sphygmomanometer
- Requirements for automated sphygmomanometer (pattern approval)
- Requirements for automated sphygmomanometer (verification)

## 7.2 Verification

### 7.2.1 Initial verification

At initial verification the requirements of 5.1 (Max. permissible error of the cuff pressure indication) and 6.5.1 (Air leakage)) shall be fulfilled.

Testing shall be carried out according to A.2 and A.6.

### 7.2.2 Subsequent verification

Each instrument of an approved type of sphygmomanometer shall be verified every 2 years or after repair. At least 5.1 and 6.5.1 shall be fulfilled and tests must be carried out according to A.2 and A.6.

## 7.3 Sealing

7.3.1 Control marks will be put on lead seals for which corresponding punched screws shall be attached whenever necessary. These seals shall prevent, without destruction of the control marks:

- in the case of patient-monitors in which the sphygmomanometer is one part of a system: the manipulation of the metrologically relevant parts for measuring blood pressure;
- in the case of all other manometers: the opening of the casing.

7.3.2 If the construction of the instrument guarantees security against any interference, the metrological control marks or the security marks may be attached in the form of labels.

7.3.3 All seals shall be accessible without using a tool.

## Three examples how to enter the verification mode:

### Example 1 and 2:

By penetrating the plug deeper into the connection for verification the pressure transducer of tested device is solely connected with the reference manometer.

In its normal configuration the plug is not so deep in the connection, thus having connection to the pressure transducer, the pump and the control valves of the automated sphygmomanometer.

### Example 3:

After removing the wrist cuff the valve has to be switched to "c" to close the pneumatic connection to the control valves.

### General remarks:

Very often the "START" and the "POWER ON" switch have to be pressed at the same time to enter the software for verification, usually the display of the systolic and the diastolic display show the pressure parallel.

Clinical monitors usually have service modes, that include manometer mode applicable for verification.

Example 1 and 2



Configuration for normal use

Example 1 and 2



Configuration for normal use, disconnected plug



Example 1 and 2



Configuration for normal use, disconnected plug;  
upper part: removed spacer, downer part: turned plug

Example 1 and 2



Configuration for verification

Example 3



Example 3



The valve has to be turned in the position c (close) for verification and after verification back to o (open) for normal use



## APEC/APLMF Training Courses in Legal Metrology (CTI-11/2006T)

### Seminar on Automated Sphygmomanometers

#### “Difference between OIML R16-2 and EN 1060”

Stephan Mieke  
Physikalisch-Technische Bundesanstalt  
Berlin

#### *OIML R16-2, 5.3.2 Temperature, relative humidity*

For the ambient temperature range of 10 °C to 40 °C and a relative humidity of 85 % (non-condensing), the difference of the cuff pressure indication of the sphygmomanometer shall not exceed ± 0.4 kPa (± 3 mmHg).

The signal processing for the determination of the blood pressure values shall not be influenced within the range of temperature and relative humidity. For any set of conditions all the deviations between the reference pressure and the indicating cuff pressure of the instrument must be less than or equal to the maximum permissible error.

#### EN 1060, Part 1, 7.1.2.2 Effect of temperature

For the ambient temperature range of 10 °C to 40 °C and the relative humidity of 85 % (non-condensing), the difference of the cuff pressure indication of the sphygmomanometer shall not exceed 3 mmHg (0,4 kPa).

#### EN 1060, Part 3, 7.5.2 Temperature, relative humidity

7.1.2.2 of EN 1060-1: 1995 shall apply.

The signal processing for the determination of the blood pressure values shall not be influenced within the range of temperature and Relative Humidity specified in 7.1.2.2 of EN 1060-1: 1995.

#### OIML R16-2, 5 Metrological requirements

##### 5.1 Maximum permissible errors of the cuff pressure indication

For any set of conditions within the ambient temperature range of 15 °C to 25 °C and the relative humidity range of 20 % to 85 %, both for increasing and for decreasing pressure, the maximum permissible error for the measurement of the cuff pressure at any point of the scale range shall be ± 0.4 kPa (± 3 mmHg) in case of verifying the first time and ± 0.5 kPa (± 4 mmHg) for sphygmomanometers in use.

#### EN 1060, Part 1, 7.1 Performance

##### 7.1.1 Limits of the error of the cuff pressure indication

At any single condition within the ambient temperature range of 15 °C to 25 °C and the relative humidity range of 20 % to 85 %, both for increasing and for decreasing pressure, the maximum error for the measurement of the cuff pressure at any point of the scale range shall be ± 3 mmHg (± 0.4 kPa).

#### *OIML R16-2, 6.11.3 Tubing connectors*

Users of equipment intended for use in environments employing intravascular fluid systems shall take all necessary precautions to avoid connecting the output of the blood pressure measuring device to such systems as air might inadvertently be pumped into a blood vessel if, for example, Luer locks were used.

#### EN 1060, Part 1, 1 Scope

....

NOTE: This standard recommends that Luer lock connectors should not be used with these devices.

#### Part 3: 7.11.3 Tubing connectors

Luer lock connectors shall not be used.

NOTE: In order to avoid possible misconnection with intravascular systems Luer slip connectors should not be used.

## OIML R16-2, 5 Metrological controls

### 7.1 Type approval

### 7.2 Verification

## OIML R16-2, 5.2 Maximum permissible errors of the overall system as measured by clinical tests\* (\* carried out by the manufacturer)

The following maximum permissible errors shall apply for the overall system:

- maximum mean error of measurement:  $\pm 0.7$  kPa ( $\pm 5$  mmHg);
- maximum experimental standard deviation: 1.1 kPa (8 mmHg).

For further recommended test methods see Annex C.

### EN 1060-3: 7.9 Overall system accuracy

Except for short term automatic mode (see 2.102 of EN 60601-2-30: 1995) and devices in which blood pressure is determined manually with the aid of a stethoscope, the following overall system accuracy values shall apply:

- a) maximum mean error of measurement:  $\pm 5$  mmHg ( $\pm 0.7$  kPa);
- b) maximum experimental standard deviation: 8 mmHg (1.1 kPa).

Testing shall be performed in accordance with EN 1060-4.

Upon request the manufacturer shall provide evidence to the Notified Body that these requirements are met.

Revised in 2005

**EN 1060:** No such clauses, because covered by European Directive

EN 1060-4, 4.3

Table 1 — Matrix for the selection of the clinical test method

Reference method	Measurement technique of the device to be tested	Clinical test method as a function of application			
		adults	neonatal mode	ergo. <sup>a</sup>	ABPM <sup>b</sup>
Auscultatory measurement at the upper arm	Continuous pressure drop or pressure drop in steps (upper arm measurement)				
	$\leq 3$ mmHg/s or $\leq 3$ mmHg/pulse <sup>c</sup>	N1/N2/N3	-	N4	N5/N6
	$> 3$ mmHg/s or $> 3$ mmHg/pulse <sup>c</sup>	N2/N3	-	-	N6
Invasive measurement	Measurement on other sites than the upper arm	N2/N3			
	Measurement during inflation phase	N2/N3	-	-	N6
	Measurement during the pressure drop or the inflation phase	1 1	1 2	-	-
<sup>a</sup> Ergometry (measurement under physical load) <sup>b</sup> Ambulatory blood pressure measurement <sup>c</sup> For devices adapting to the pulse rate					

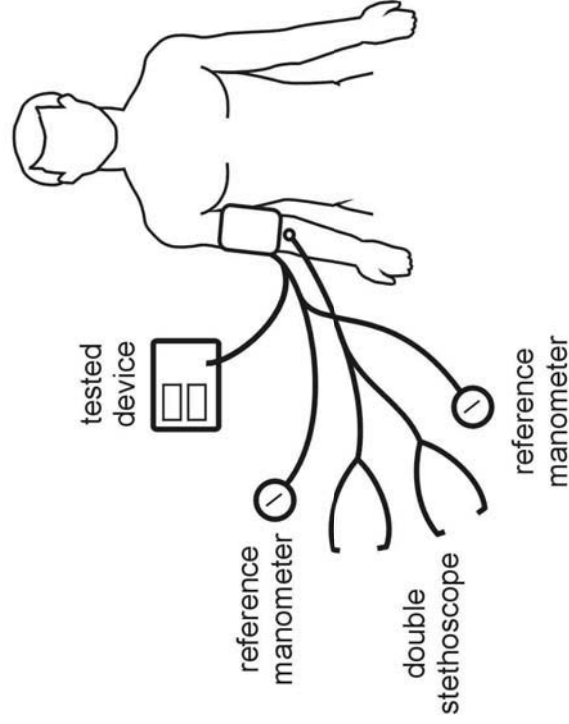

Fig: Clinical test set-up according EN 1060-4 (N1) for devices with deflation rates up to 3 mmHg/s.

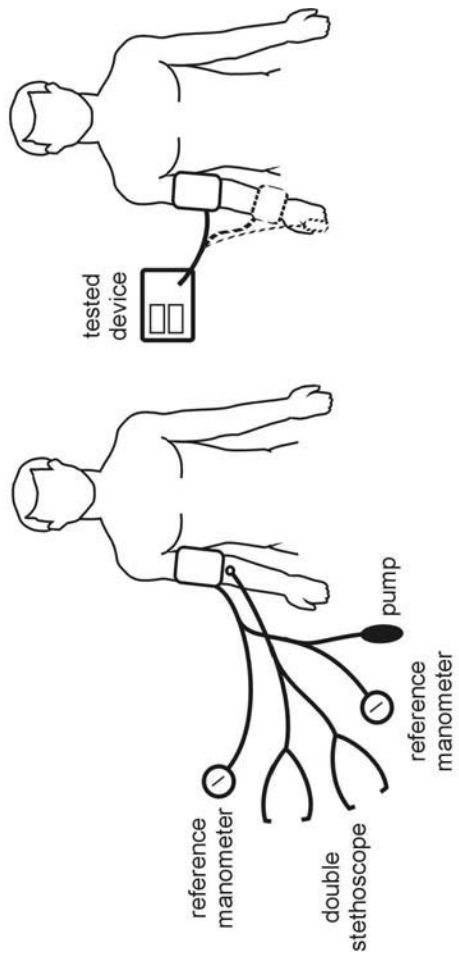

Fig.: Clinical test set-up according EN 1060-4 (N3) for devices with deflation rates higher than 3 mmHg/s (sequential measurement).



## APEC/APLMF Training Courses in Legal Metrology (CTI-11/2006T)

### Seminar on Automated Sphygmomanometers

#### “The traceability of medical device”

Stephan Mieke

Physikalisch-Technische Bundesanstalt  
Berlin

## Traceability of medical devices

Classical way (“hard metrology”):

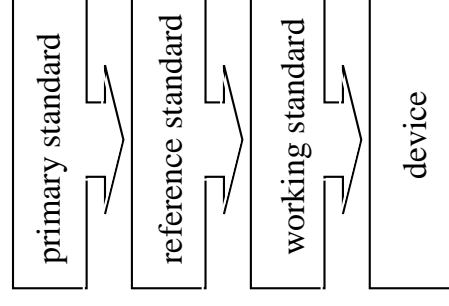

## Traceability of medical devices

What is special for medical devices with a measuring function?

Usually the measurement is based on **physiological models**,

e.g. intra-ocular pressure. All non-invasive intra-ocular pressure measurements are based on a comparative study of direct and indirect measurements on approximately 10 eyes of dead people performed once by Hans Goldmann in Switzerland in 1955. The results were adopted by the medical community and became the "gold standard" to this day for this kind of measurement.

## Traceability of medical devices

“Soft metrology”:

### Problem:

intra-individual and inter-individual variations

### How the problem is addressed:

metrology based on

- > accepted diagnostic/therapeutic limits (**soft I**),
- > database of clinical data for **general** application (**soft II**),
- > individual clinical trial for a **specific** device (**soft III**)

Traceability of medical devices

hard metrology	soft metrology		
	soft I	soft II	soft III
primary standard	primary standard	database of test signals	one clinically tested device
reference standard	reference standard	test device/generator	transfer standard
working standard	working standard		
device	device	device	device

Traceability of medical devices

hard metrology	soft metrology		
	soft I	soft II	soft III
primary standard	primary standard	database of test signals	one clinically tested device
reference standard	reference standard	test device/generator	transfer standard
working standard	working standard		
device	device	device	device

Traceability of medical devices: soft I



**Medical device:**  
liquid-in-glass thermometer,  
electrical thermometer

working standard: water bath  
reference standard: calibrated thermometer  
primary standard: international temperature scale (ITS 90)



Traceability of medical devices: soft I



**Medical device:**  
infra-red ear thermometer

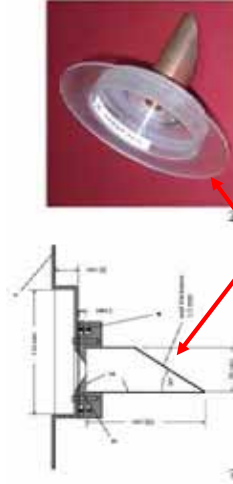

working standard: reference bath black body radiator  
reference standard: calibrated thermometer  
primary standard: international temperature scale (ITS 90)

Traceability of medical devices: soft I

**Medical device:**  
sphygmomanometer

working standard: calibrated pressure meter  
reference standard: pressure balance  
primary standard: PTB standards for force and length



Traceability of medical devices: soft I

**Medical device:**  
ergometer



working standard: calibrator  
reference standard: PTB standard for dynamic rotatory power  
primary standard: PTB standards for torque, length, time

Traceability of medical devices

hard metrology	soft metrology		
	soft I	soft II	soft III
primary standard	primary standard	database of test signals	one clinically tested device
reference standard	reference standard	test device/generator	transfer standard
working standard	working standard		
device	device	device	device

Traceability of medical devices: soft II

**Medical device:**  
peak expiratory flow meter

test generator: pump system  
(calibrated by PTB standard for dynamic flow)  
database of test signals: waveforms

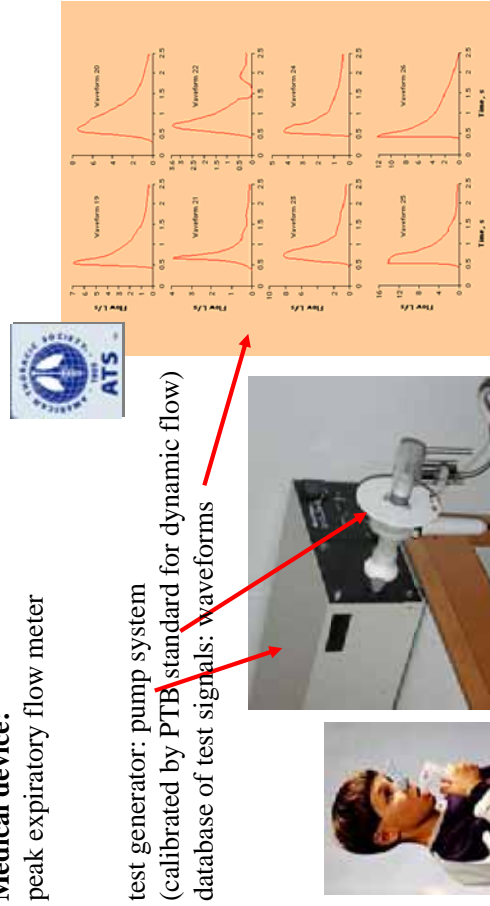

Traceability of medical devices

hard metrology	soft metrology		
	soft I	soft II	soft III
primary standard	primary standard	database of test signals	one clinically tested device
reference standard	reference standard	test device/generator	transfer standard
working standard	working standard		
device	device	device	device

Traceability of medical devices: soft III

**Medical device:**  
air puff eye tonometer

transfer standard: PTB test device (flapper)  
clinically tested medical device:  $\geq 150$  eyes

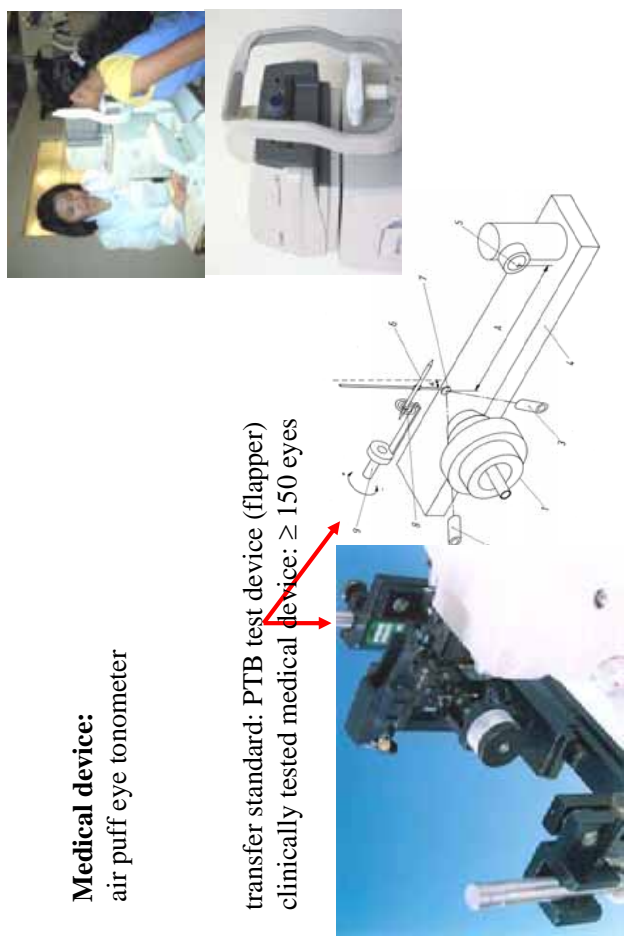

Traceability of medical devices: soft III

**Medical device:**  
automated sphygmomanometer

transfer standard: software version for the determination of the blood pressure values  
clinically tested medical device:  $\geq 85$  subjects

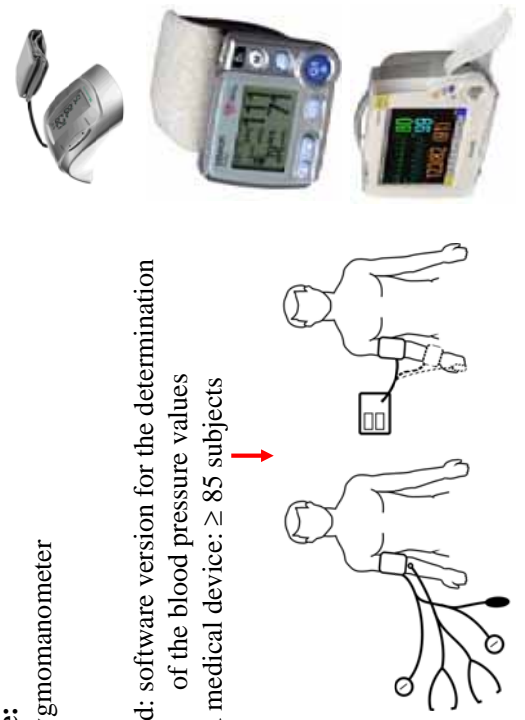

Traceability of medical devices: soft III

New development:  
EU project "Simulator for nibp" (2002-2005)  
Substitution of clinical trial by  
database of validated oscillograms,  
at present: > 1000 signals from > 600 subjects

soft II

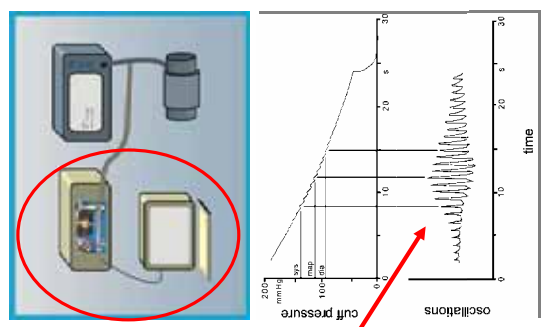



**Medical device:**  
audiometer



transfer standard: artificial ear  
clinically tested medical device:  
hearing threshold determined at 25 young subjects



Metrology for medical devices with a measuring function is different from traditional metrology, because physiological assumptions have to be taken into account in most cases. Furthermore primary standards are not always available, it is necessary to replace them by an accepted database or by individually clinically tested devices.

Traceability of medical devices: PTB activities

PTB group	topic (task)	contact
1.6	Medical Acoustics/Ultrasound (audiometer, ultrasound devices)	Christian Koch
3.1	Metrology in Chemistry	Bernd Güttler
6.2	Dosimetry for Radiotherapy (brachytherapy, alanine dosemeter probes)	Hans-Michael Kramer
7.31	Temperature Radiation (infra-red ear thermometer)	Jörg Hollandt
7.42	Applied Thermometry (clinical thermometer)	Erich Tegeler
8.11	NMR Measuring Techniques (RF power deposition in MRI)	Frank Seifert / Bernd Itermann
8.12	Standards for Medical Measuring Techniques (eye tonometer, sphygmomanometer, ergometer, spirometer)	Stephan Miese
8.32	Flow Cytometry and Microscopy (full blood count)	Jörg Neukammer

Thank you !



**APEC/APLMF Training Courses in Legal Metrology (CTI-11/2006T)**

**Seminar on Automated Sphygmomanometers**

**‘European Standards on Sphygmomanometers’**

Stephan Mieke  
 Physikalisch-Technische Bundesanstalt  
 Berlin

**EN 1060 : Structure**

EN 1060 Non-invasive sphygmomanometers

- EN 1060-1 General requirements (1995)
- EN 1060-2 Supplementary requirements for mechanical sphygmomanometers (1995)
- EN 1060-3 Supplementary requirements for electro-mechanical blood pressure measuring systems (1997 / 2005)
- EN 1060-4 Test procedures to determine the overall system accuracy of automated non-invasive sphygmomanometers (2004)

**EN 1060 : Structure**

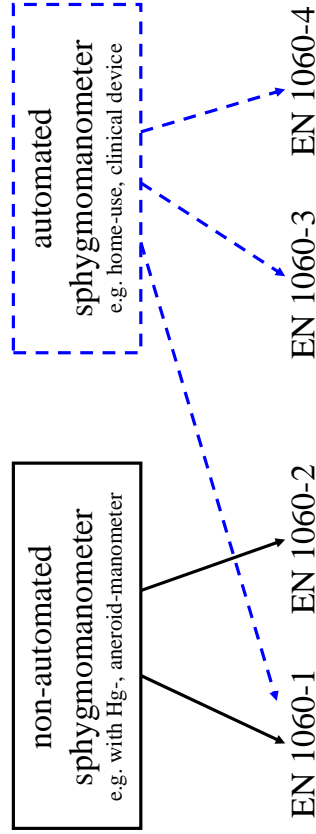

**EN 1060 : Part 1**

EN 1060 Non-invasive sphygmomanometers

- EN 1060-1 General requirements (1995)
- EN 1060-2 Supplementary requirements for mechanical sphygmomanometers (1995)
- EN 1060-3 Supplementary requirements for electro-mechanical blood pressure measuring systems (1997 / 2005)
- EN 1060-4 Test procedures to determine the overall system accuracy of automated non-invasive sphygmomanometers (2004)

#### 4 Cuff

The cuff shall contain a bladder. For reusable cuffs the manufacturer shall indicate the method for cleaning in the accompanying documents (see 9.2).

**NOTE:** The Optimum bladder size is one with dimensions such that its width is 40 % of the limb circumference at the centre of the range for each cuff size and that its length is 80 % to 100 % of the limb circumference at the centre of the range for each cuff size. Use of the wrong size can affect the accuracy of the measurement. These recommended dimensions are subject to ongoing consideration.

#### 5 Display

The display shall be designed and arranged so that the information including measuring values can be read and easily recognized.

Testing shall be carried out by visual inspection.

If abbreviations are used on the display they shall be as follows:

”S” or ”SYS”: systolic blood pressure (value);  
 ”D” or ”DIA”: diastolic blood pressure (value);  
 or ”MAP”: mean arterial blood pressure (value).

Single letter abbreviations shall be positioned in such a way to avoid confusion with SI units.

#### 6 Units

The blood pressure shall be indicated in either millimetres of mercury (mmHg) or kilopascals (kPa).

##### 7.1.1 Limits of the error of the cuff pressure indication

At any single condition within the ambient temperature range of 15 °C to 25 °C and the relative humidity range of 20 % to 85 %, both for increasing and for decreasing pressure, the maximum error for the measurement of the cuff pressure at any point of the scale range shall be  $\pm 3$  mmHg ( $\pm 0,4$  kPa).

**8.1** Method of test for the limits of error of the cuff pressure indication

##### 8.1.1 Apparatus

- rigid metal vessel with a capacity of 500 ml  $\pm 5$  %;
- calibrated reference manometer with an error less than 0,8 mm/Hg (0,1 kPa);

...

##### 8.1.2 Procedure

...

- Carry out the test in pressure steps of not more than 50 mmHg between 0 mmHg and the maximum pressure of the scale range.

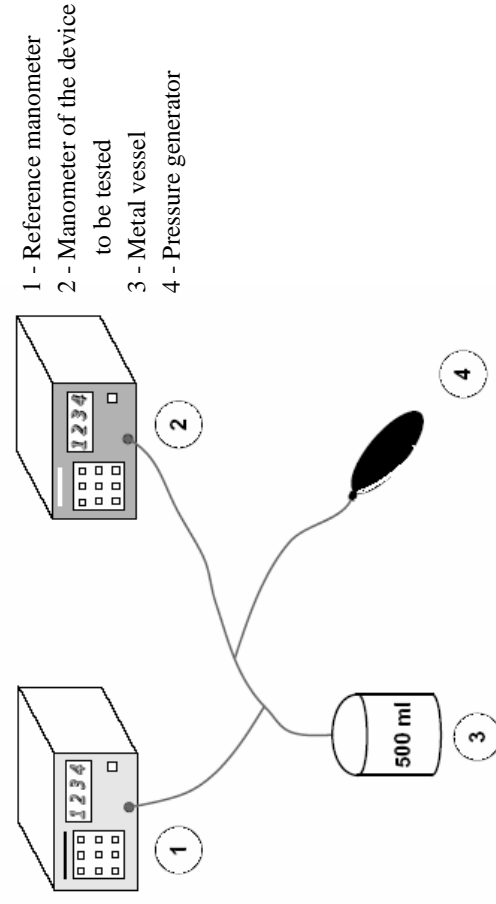

**Figure:** Test rig for determining the limits of error of the cuff pressure indication



**Figure:** Measurement setup to determine the limits of error of the cuff pressure indication (home use device)

### 7.1.2 Environmental performance

#### 7.1.2.2 Effect of temperature

For the ambient temperature range of 10 °C to 40 °C and the relative humidity of 85 % (non-condensing), the difference of the cuff pressure indication of the sphygmomanometer shall not exceed 3 mmHg (0,4 kPa).

### 7.1.2 Environmental performance

#### 7.1.2.1 Effect of storage

The sphygmomanometer shall maintain the requirements specified in this standard after storage for 24 h at a temperature of -20 °C and for 24 h at a temperature of 70 °C and a relative humidity of 85 % (non-condensing).

Testing shall be carried out in accordance with 8.1 at environmental conditions described in 7.1.1 after the test sample has been placed for 24 h at a temperature of -20 °C and immediately afterwards for 24 h at a temperature of 70 °C in a climatic chamber.

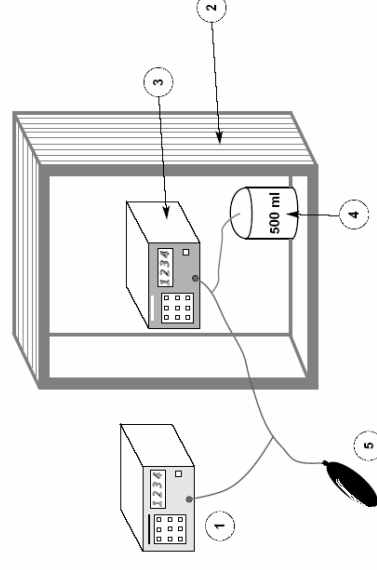

- 1 - Reference manometer
- 2 - Climatic chamber
- 3 - Device to be tested
- 4 - Metal vessel
- 5 - Pressure generator

**Figure:** Measurement system for determining the influence of temperature

EN 1060 Non-invasive sphygmomanometers

- EN 1060-1 General requirements (1995)
- EN 1060-2 Supplementary requirements for mechanical sphygmomanometers (1995)
- EN 1060-3 Supplementary requirements for electro-mechanical blood pressure measuring systems (1997 / 2005)
- EN 1060-4 Test procedures to determine the overall system accuracy of automated non-invasive sphygmomanometers (2004)

**7.1.3.1 Air leakage**

Air leakage shall not exceed a pressure drop of 4 mmHg/min (0,5 kPa/min).

**7.1.3.2 Pressure reduction rate**

Manually operated and self-linearizing deflation valves shall be capable of adjustment to a deflation rate of (2 to 3) mmHg/s ((0,3 to 0,4) kPa/s).

Manually operated deflation valves shall be easily adjusted to these values.

Self-linearizing valves shall be tested in accordance with 8.2.

**7.2.3 Mechanical safety**

It shall be possible to abort the blood pressure measurement at any time by activating the manual rapid exhaust valve, which shall be easily accessible.

**7.2.4 Tamper proofing**

Tamper proofing of the manometer shall be achieved by requiring the use of a tool or the breaking of a seal.

**7.3 Additional requirements for mercury manometer**

**7.3.1 Internal diameter of the tube containing mercury**

The nominal internal diameter of the tube containing mercury shall be at least 3,5 mm. The tolerance on diameter shall not exceed  $\pm 0,2$  mm. (See also 9.3b)).

**7.3.2 Portable devices**

A portable device shall be provided with an adjusting or locking mechanism to secure it in the specified position for use.

### 7.3.3 *Tube containing mercury and reservoir*

A locking device shall be placed between the reservoir and the tube to prevent the spillage of mercury during transport.

### 7.3.4 *Stopping device in the tube containing mercury and reservoir*

A stopping device shall be incorporated in the reservoir and the tube, which shall prevent the mercury from being spilled during transport and use. The delay in the setting of the mercury column due to the stopping device shall not exceed 1,5 s for the flow of the mercury from 200 mmHg to 50 mmHg (from 25 kPa to 5 kPa) when die pressure in the system drops rapidly from 200 mmHg to 0 mmHg (from 25 kPa to 0 kPa).

### 7.4.4 *Hysteresis error*

The hysteresis error throughout the pressure range shall be within the range 0 mmHg to 4 mmHg (0 kPa to 0,5 kPa).

### 7.4.5 *Construction and materials*

The construction of the aneroid manometer and the material for the elastic sensing elements shall ensure an adequate stability of the measurement. The elastic sensing elements shall be aged with respect to pressure and temperature.

The difference in the pressure indication of the aneroid manometer before and after 10000 alternating pressure cycles shall be not more than 3 mmHg (0,4 kPa) throughout the pressure range.

## 7.4 Additional requirements for aneroid manometer

### 7.4.1 *Scale mark at zero*

If a tolerance zone is shown at zero it shall not exceed  $\pm 3$  mmHg ( $\pm 0,4$  kPa) and shall be clearly marked.

A scale mark at zero shall be indicated.

NOTE: Graduations within the tolerance zone are optional.

### 7.4.2 *Zero*

The movement of the elastic sensing element including the pointer shall not be obstructed within 6 mmHg (0,8 kPa) below zero.

Neither the dial nor the pointer shall be adjustable by the user.

## 9 Information to be supplied by the manufacturer

### 9.1 ...

### 9.2 Instruction leaflet

Items a), b) and c) of subclause 9.2 of EN 1060-1:1995 shall apply with the following addition:

a) nature and frequency of the maintenance to ensure that the device operates properly and safely at all times;

NOTE: It is recommended that the performance should be checked at least every 2 y and after maintenance and repair, by re-testing at least the requirements in 7.1.1, 7.1.3.1 (testing at least at 50 mmHg and 200 mmHg) and 7.3.4. c) internal nominal diameter and tolerance of the tube containing mercury; d) detailed instructions for the safe handling of mercury (see annex B).

EN 1060 Non-invasive sphygmomanometers

- EN 1060-1 General requirements (1995)
- EN 1060-2 Supplementary requirements for mechanical sphygmomanometers (1995)
- EN 1060-3 Supplementary requirements for electro-mechanical blood pressure measuring systems (1997 / 2005)
- EN 1060-4 Test procedures to determine the overall system accuracy of automated non-invasive sphygmomanometers (2004)

**1 Scope**

This Part of EN 1060 specifies performance, efficiency and safety requirements for electro-mechanical blood pressure measuring systems that, by means of an inflatable cuff are used for non-invasive measurements of arterial blood pressure at the upper arm, the wrist and the thigh. It also specifies requirements for their accessories and gives test methods.

This Part of EN 1060 applies to electro-mechanical blood pressure measuring systems in which the cuff pressure is measured electronically, but in which the blood pressure can be determined either manually with the aid of a stethoscope or automatically.

Additional safety requirements for automatic cycling indirect blood pressure monitoring equipment are specified in EN 60601-2-30: 1995.

**7.3 Effect of voltage variations of the power source variations**

*7.3.1 Internal electrical power source*

- a) Blood pressure measuring systems in which the cuff pressure is generated by an electrical pump shall comply with 56.7 of EN 60601-2-30: 1995;
- b) Changes of the voltage within the working range determined in 8.2.1 shall not influence the cuff pressure reading and the result of the blood pressure measurement;
- c) Outside of the working range, no cuff pressure reading and no result of the blood pressure measurement shall be displayed.

*7.3.2 External electrical power source*

- a) Blood pressure measuring systems in which the cuff pressure is generated by an electrical pump shall comply with 49.3 and 49.101 of EN 60601-2-30: 1995;
- b) Changes of the voltage within the working range specified by the manufacturer (see 9.2) shall not influence the cuff pressure reading and the result of the blood pressure measurement.
- c) Incorrect values resulting from voltage variations outside the limits given in 7.3.2 b) shall not be displayed.

## 7.4 Pneumatic system

### 7.4.1 Air leakage

Air leakage shall not exceed a pressure drop of 6 mmHg/min (0,8 kPa/min). ...

### 7.4.3 Rapid exhaust

During the rapid exhaust of the pneumatic system with fully opened valve, the time for the pressure reduction from 260 mmHg to 15 mmHg (34,7 kPa to 2,0 kPa) shall not exceed 10 s.

For blood pressure measuring systems having the capability to measure in a neonatal/infant mode, the time for the pressure reduction from 150 mmHg to 5 mmHg (20,0 kPa to 0,7 kPa) during the rapid exhaust of the pneumatic system with fully opened valve shall not exceed 5s.

### 7.4.4 Zero setting

Blood pressure measuring systems shall be capable of automatic zero setting. The zero setting shall be carried out at appropriate intervals, at least starting after switching on the device. At the moment of the zero setting a gauge pressure of 0 mmHg (0 kPa) shall exist and be displayed thereafter.

Devices performing zero setting only immediately after switching on, shall switch off automatically before the drift of the pressure transducer and the analog signal processing exceeds 1 mmHg (0,1 kPa).



Figure: Air leakage test set-up

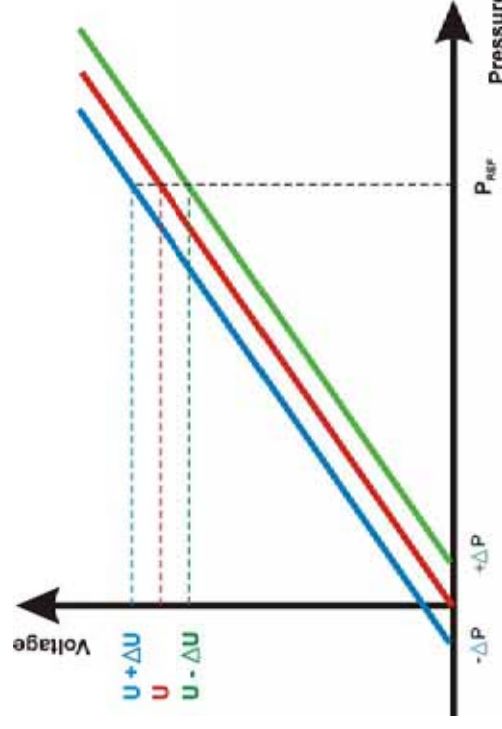

Figure: Applying positive or negative pressure at the moment of zero setting will result in a decrease or increase of voltage (or displayed pressure), thus proving that the zero setting software works correctly.



## 7.5 Environmental performance

### 7.5.1 Storage

Blood pressure measuring systems shall maintain the requirements specified in this Part of EN 1060 after storage for 24 h at a temperature of  $-5\text{ }^{\circ}\text{C}$  and for 24 h at a temperature of  $+50\text{ }^{\circ}\text{C}$  and a Relative Humidity of 85 % (non-condensing).

Testing shall be carried out at environmental conditions (see 7.1.1 of EN 1060-1:1995) in accordance with 8.1 of EN 1060-1: 1995 after the test sample has been placed for 24 h at a temperature of  $-5\text{ }^{\circ}\text{C}$  and immediately afterwards for 24 h at a temperature of  $+50\text{ }^{\circ}\text{C}$  in a climatic chamber.

NOTE: Integrated multiparameter monitors may contain components which can be damaged during storage. The general temperature range in EN 1060-1: 1995 has therefore been reduced.

### 7.5.2 Temperature, relative humidity

7.1.2.2 of EN 1060-1: 1995 shall apply.

The signal processing for the determination of the blood pressure values shall not be influenced within the range of temperature and Relative Humidity specified in 7.1.2.2 of EN 1060-1: 1995.



Figure: Measurement set-up to determine the stability of the blood pressure determination; left: simulator, right open climatic chamber with automated sphygmomanometer

### 7.5.3 Electromagnetic compatibility

Either:

a) Electrical and/or electromagnetic interferences shall not lead to degradations in the cuff pressure indication or in the result of the blood pressure measurement,

or;

b) if electrical and/or electromagnetic interferences lead to an abnormality, the abnormality shall be clearly indicated and it shall be possible to restore normal operation within 30 s after cessation of the electromagnetic disturbance.

Testing shall be carried out in accordance with EN 60601-1-2: 1993.

### 7.6 Stability of the cuff pressure indication

The change of the cuff pressure indication shall not be more than 3 mmHg (0,4 kPa) throughout the pressure range after 10 000 simulated measurement cycles.

### 7.7 Pressure indicating device

#### 7.7.1 Nominal range and measuring range

The nominal range for the cuff pressure measurement shall be specified by the manufacturer.

The measuring and indication ranges of the cuff pressure shall be equal to the nominal range.

Values of blood pressure measurement results outside the nominal range of cuff pressure shall be clearly indicated as out of range.

#### 7.7.2 Digital indication

The numerical step shall be 1 mmHg (0,1 kPa).

Numbers shall be clearly legible in accordance with clause 6 of EN 60601-1: 1990.

If the measured value of a parameter is to be indicated on more than one display, all the displays shall indicate the same numerical value.

Measured, numerical values on the display(s), and the symbols defining the units of measurement shall be arranged in such a way so as to avoid misinterpretation.

### 7.9 Overall system accuracy

Except for short term automatic mode and devices in which blood pressure is determined manually with the aid of a stethoscope, the following overall system accuracy values shall apply:

- a) maximum mean error of measurement:  $\pm 5$  mmHg ( $\pm 0,7$  kPa);
- b) maximum experimental standard deviation: 8 mmHg (1,1 kPa).

Testing shall be performed in accordance with EN 1060-4.

Upon request the manufacturer shall provide evidence to the Notified Body that these requirements are met.

(EN 1060-3:1997/A1:2005)

## 7.11 Safety

### 7.11.1 Cuff pressure

It shall be possible to abort any blood pressure measurement at any time by single key operation and this shall lead to a rapid exhaust (see 7.4.3).

### 7.11.2 Unauthorized access

All controls that affect accuracy shall be sealed against unauthorized access.

### 7.11.3 Tubing connectors

Luer lock connectors shall not be used.

NOTE: In order to avoid possible misconnection with intravascular systems Luer slip connectors should not be used.

## 1 Scope

This document describes test procedures for investigations to determine the overall system accuracy of automated non-invasive sphygmomanometers, designed for the indirect measurement of blood pressure.

## EN 1060 Non-invasive sphygmomanometers

- EN 1060-1 General requirements (1995)
- EN 1060-2 Supplementary requirements for mechanical sphygmomanometers (1995)
- EN 1060-3 Supplementary requirements for electro-mechanical blood pressure measuring systems (1997 / 2005)
- EN 1060-4 Test procedures to determine the overall system accuracy of automated non-invasive sphygmomanometers (2004)

### 4.1 General information on the non-invasive reference methods

...

The auscultatory blood pressure measurements described shall be carried out by two observers by means of a double stethoscope. The auscultatory reference value will then be the mean value of the two values determined by the observers. The difference between both values shall not exceed 4 mmHg. Any measurements with observer-to- observer differences greater than 4 mmHg shall not be included in the data set. The number of discarded measurements shall not be greater than the number of the required valid measurements.

...

The calibrated reference manometers shall comply with the requirements of EN 1060-1 to EN 1060-3 but shall not exceed error limits of 1 mmHg (0,1 kPa) with dropping cuff pressure prior to the start of the clinical investigation.

Table 1 — Matrix for the selection of the clinical test method

Reference method	Measurement technique of the device to be tested	Clinical test method as a function of application				ABPM <sup>b</sup>
		adults	neonatal mode	ergo. <sup>a</sup>		
	Continuous pressure drop or pressure drop in steps (upper arm measurement) ≤ 3 mmHg/s or ≤ 3 mmHg/pulse <sup>c</sup> > 3 mmHg/s or > 3 mmHg/pulse <sup>c</sup>	N1/N2/N3 N2/N3	-	N4	N5/N6 N6	
Auscultatory measurement at the upper arm	Measurement on other sites than the upper arm	N2/N3	-	-	N6	
Invasive measurement	Measurement during inflation phase	N2/N3	-	-	-	
	Measurement during the pressure drop or the inflation phase	1 1	1 2	-	-	

a Ergometry (measurement under physical load)  
 b Ambulatory blood pressure measurement  
 c For devices adapting to the pulse rate

**4.6 Subjects**  
**4.6.1 General**

The selection of the subjects and their number depends on the intended purpose (...) of the device to be tested.

Limits of application stated in the users manual shall be taken into account, e.g. concerning arrhythmia (see also 4.8).

If no special purpose is intended, e.g. measurement during pregnancy, the following applies only for adults and children:

- at least 40 % shall be male and at least 40 % shall be female;
- between 50 % and 75 % shall be older than 50 years;
- between 50 % and 75 % shall have a circumference of the arm, which lies within the upper half of the specified range of use of the cuff (if applicable);
- between 50 % and 75 % shall have a circumference of the wrist, which lies within the upper half of the specified range of use of the cuff (if applicable);
- at least 10 % below 110 mmHg systolic blood pressure;
- at least 10 % above 160 mm Hg systolic blood pressure;
- at least 10 % below 70 mmHg diastolic blood pressure;
- at least 10 % above 100 mm Hg diastolic blood pressure.

**4.6.2 Non-invasive reference measurement**

**4.6.2.1 General**

A minimum of 3 measurements shall be carried out on each of at least 85 subjects.

**4.6.2.2 Additional requirements for sphygmomanometers measuring under physical load**

At least 6 paired measurements shall be carried out on each of at least 85 subjects. As much as possible, female and male subjects shall be evenly distributed while at most

25 % shall originate from the field of sports medicine.

The different blood pressure groups (see 4.6.1) shall be classified in accordance with the first valid blood pressure reference measurements at rest.

**4.6.2.3 Additional requirements for ambulatory sphygmomanometers**

At least 6 paired measurements shall be carried out on each of at least 85 subjects. The different blood pressure groups (see 4.6.1) shall be classified in accordance with the first valid blood pressure reference measurements at rest.

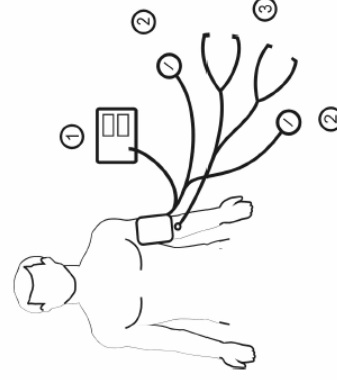

Key

- 1 Tested device
- 2 Reference manometer
- 3 Double stethoscope

Figure 1 — Schematic drawing of the simultaneous blood pressure measurement on the same arm at the same time

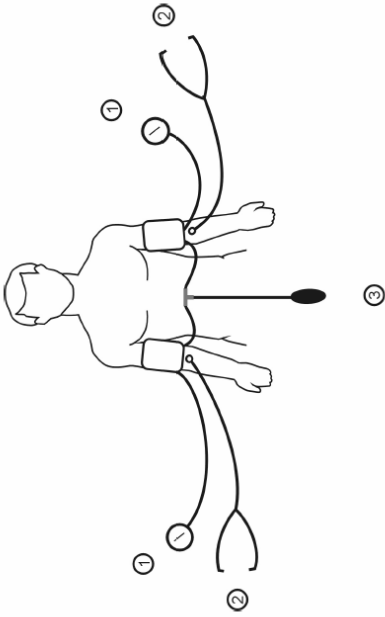

N 2

**Key**  
 1 Reference manometer  
 2 Stethoscope  
 3 Pump connected via a t-piece with the cuffs  
**NOTE** One reference manometer can be used, only if it is guaranteed that both observers can read the values without error (e.g. parallax error).

Figure 2 — Schematic drawing of blood pressure measurement in both arms before and after the paired measurements (see 5.2.1.3 and Figure 3)

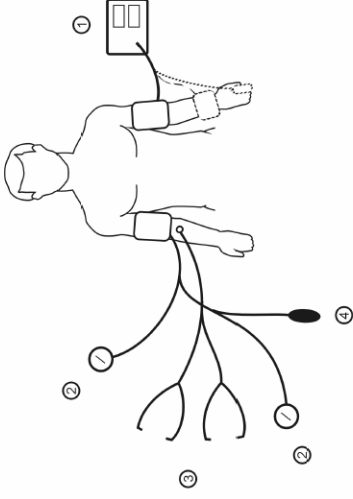

N 2

**Key**  
 1 Tested device  
 2 Reference manometer  
 3 Double stethoscope  
 4 Pump  
**NOTE** One reference manometer can be used, only if it is guaranteed that both observers can read the values without error (e.g. parallax error).

Figure 3 — Schematic drawing of the paired blood pressure measurement on opposite arms at the same time with the sphygmomanometer under test

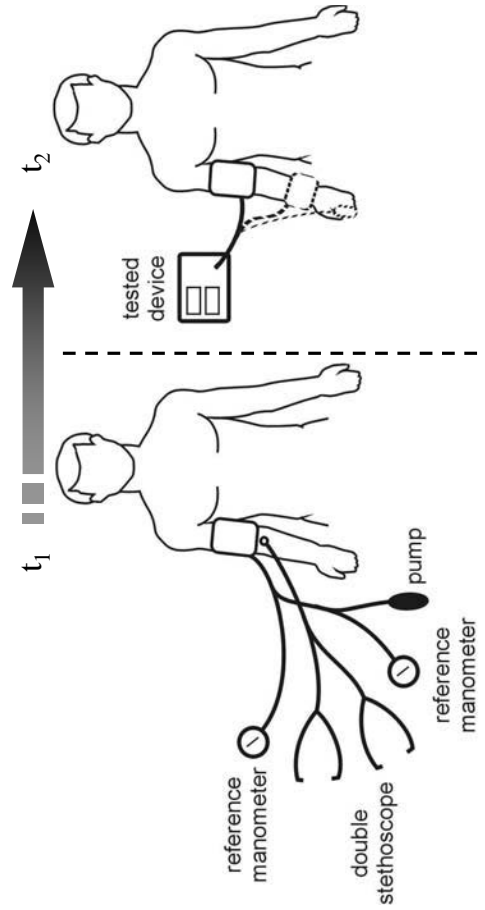
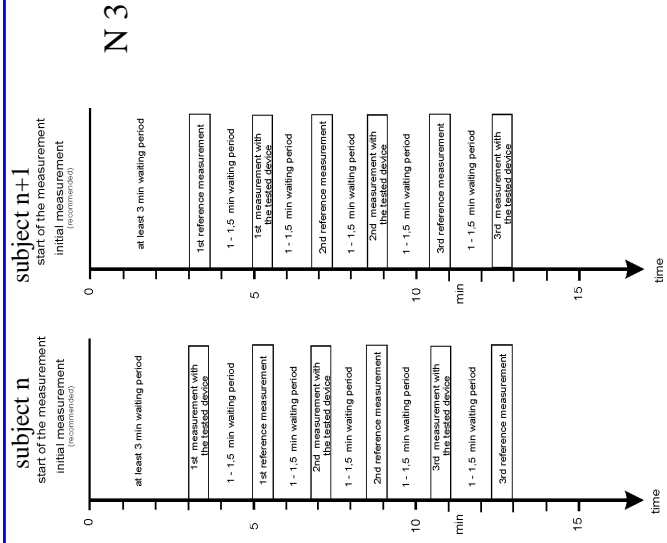

Fig.: Clinical test set-up according N 3 for devices with deflation rates higher than 3 mmHg/s (sequential measurement).



**Thank you  
for your attention!**

# European simulator to test automated sphygmomanometer

Stephan Mieke  
Physikalisch-Technische Bundesanstalt  
Berlin

## Acknowledgements:

The development was funded by a grant from the European Community under the  
"Competitive and Sustainable Growth" programme,  
grant G6RD-CTC-2002-00706.

Part of the presentation is taken from a presentation "The future for simulators-  
Towards a better validation of blood pressure measuring devices" held at the ESH  
meeting in Madrid, June 2006 by John Amoore, Alan Murray, Stephan Mieke

## Structure

- Accuracy requirements
- Why simulators ?
- Design of simulators
- Results from measurements with simulators
- Outlook

## Accuracy requirements

EN 1060, part 3, clause 7.9 Overall system accuracy:

... the following overall system accuracy shall apply:

- a) max. mean error of measurement:  $\pm 5$  mmHg
- b) max. experimental standard deviation: 8 mmHg

## Accuracy requirements

Test methods (clinical trials):

- EN 1060-4
- BHS Protocol
- ANSI/AAMI SP 10
- ESH Protocol

## Structure

- Accuracy requirements
- **Why simulators ?**
- Design of simulators
- Results from measurements with simulators
- Outlook

## Why simulators ? What determines accuracy?

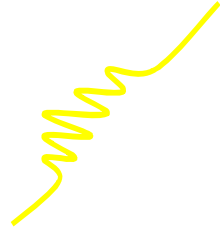

### Algorithm

Set of empirical rules determine blood pressure

### Pressure Transducer

#### Conventional static calibration.

Oscillometric pressure pulses on Cuff Pressure

### How is this verified?

Statistical comparison in 85 subjects

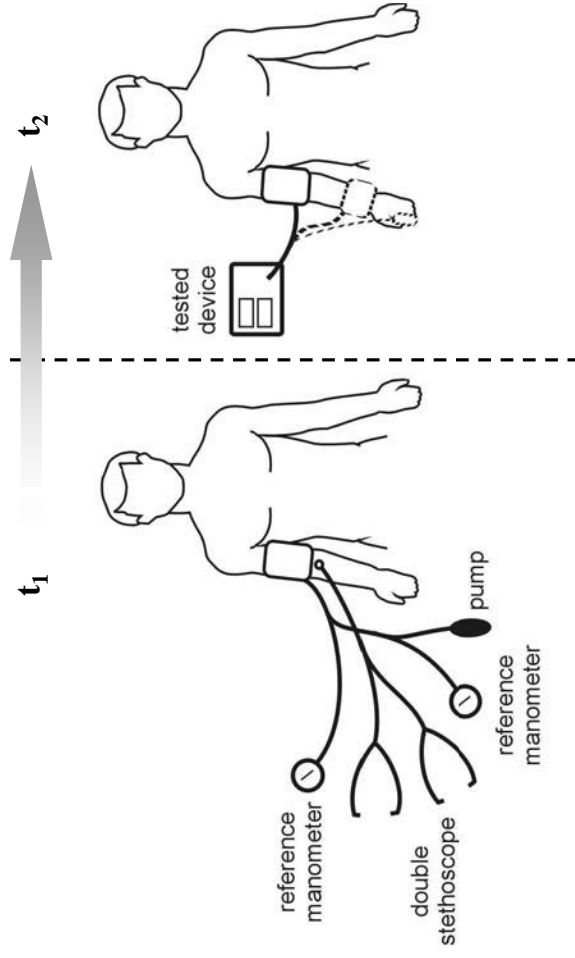
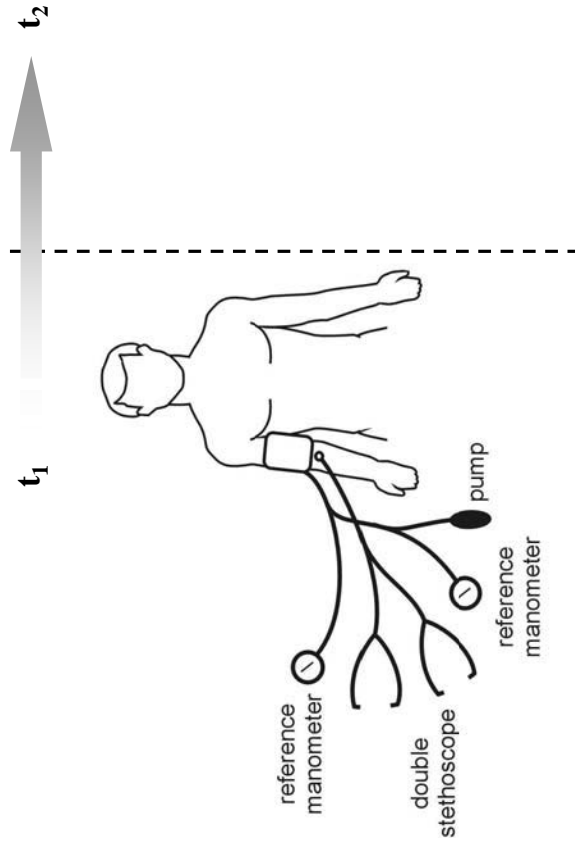

Fig.: Clinical test set-up according EN 1060-4 for devices with deflation rates higher than 3 mmHg/s (sequential measurement).

Fig.: Clinical test set-up according EN 1060-4 for devices with deflation rates higher than 3 mmHg/s (sequential measurement).



# Why simulators ?

## Clinical test:

- Clinical tests are limited to 85 subjects due to time and costs.
- Lack of inclusion of different population groups  
(Device inaccuracy in certain population groups).
- Clinical tests are hardly determining the limits of application.
- The results of clinical tests are a mixture of device related as well as procedure related errors (e.g. digital preferences, too high deflation rates); it is hardly possible to differ between both.
- Variability of findings in different clinical studies.
- Repeatability tests cannot be performed with clinical tests.

# Structure

- Accuracy requirements
- Why simulators ?
- **Design of simulators**
- Results from measurements with simulators
- Outlook

# Design of simulators

There are two different approaches to the design of simulators:

- the artificial limb

# Design of simulators

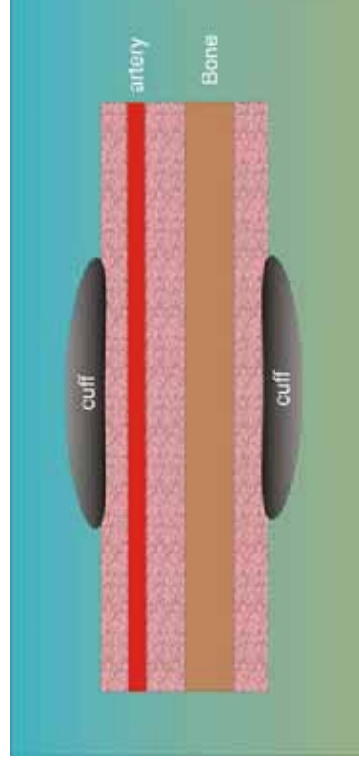

Fig.: the artificial limb

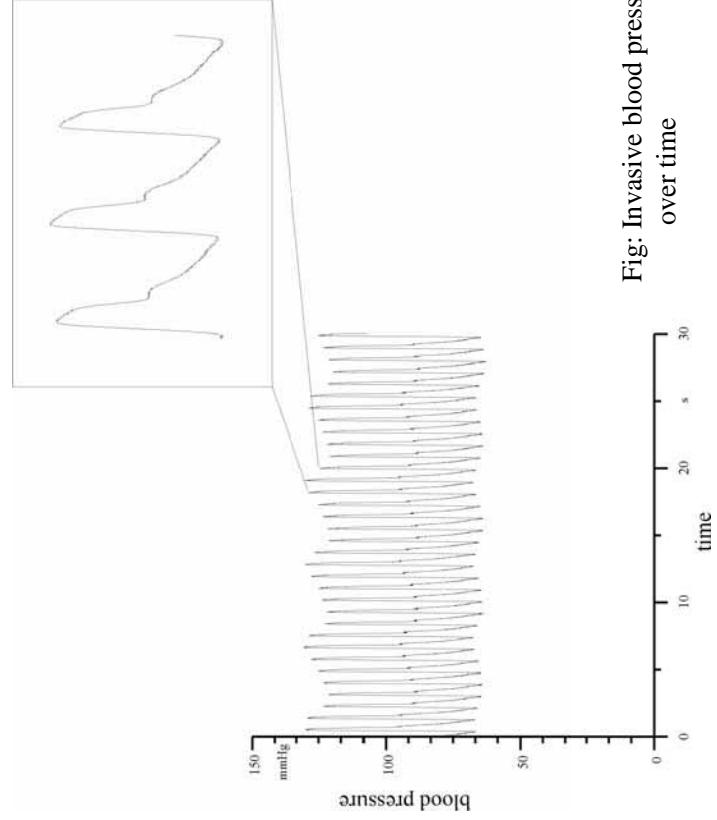

Fig: Invasive blood pressure over time

# Design of simulators

There are two different approaches to the design of simulators:

- the artificial limb
- the signal generator

# Design of simulators

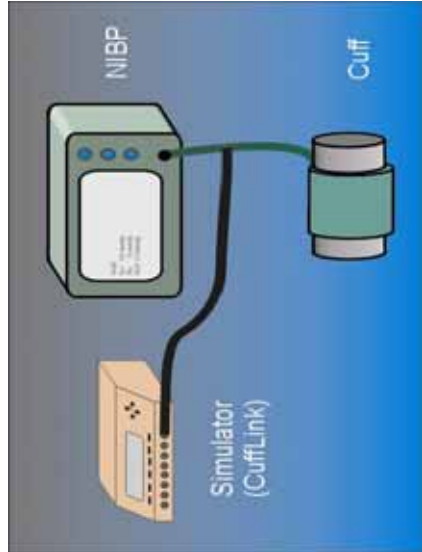
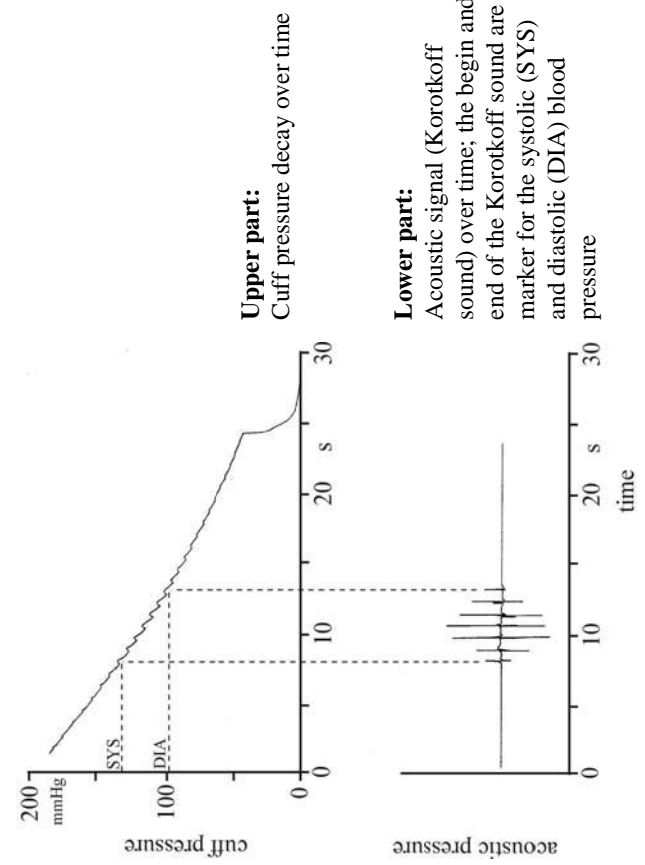

Fig.: the signal generator



Upper part:

Cuff pressure decay over time

Lower part:

Acoustic signal (Korotkoff sound) over time; the begin and end of the Korotkoff sound are marker for the systolic (SYS) and diastolic (DIA) blood pressure

# Oscillometric method

The oscillometric method was developed based on empirical data.

On the basis of extensive investigations, the following relations have been discovered:

1. The maximum of the oscillation amplitude  $A_{\max}$  coincides with the mean arterial blood pressure, in short MAP.
2. The systolic blood pressure is determined at about  $0.5 A_{\max}$ .
3. The diastolic blood pressure is determined at about  $0.8 A_{\max}$ .

Note 1:

Only the principle underlying the procedure most frequently applied has been described here; to improve its reliability, the method has been refined and extended in many aspects.

Note 2:

The factors given above are those roughly valid for measurements at the upper arm. The factors for the wrist are totally different.

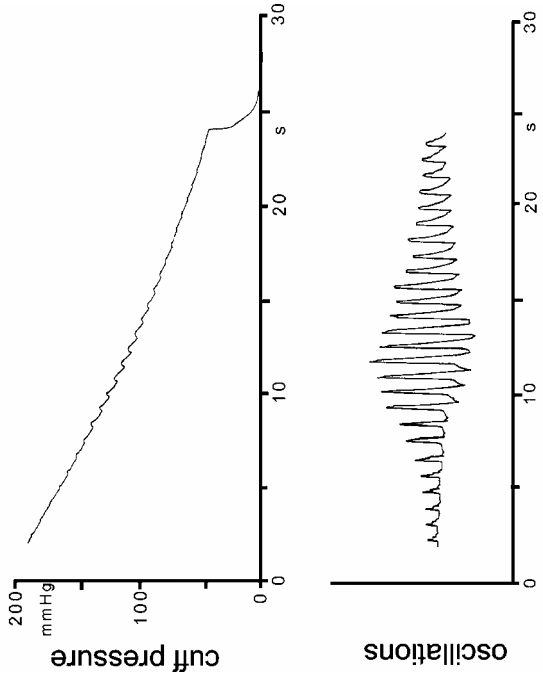

Fig.: upper part: curve of deflating cuff pressure, lower part: amplitude of pressure oscillations

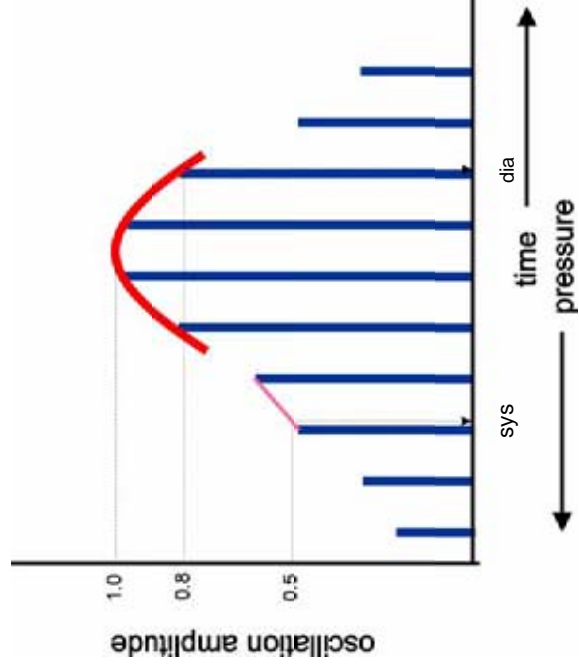

Fig.: Oscillometric principle

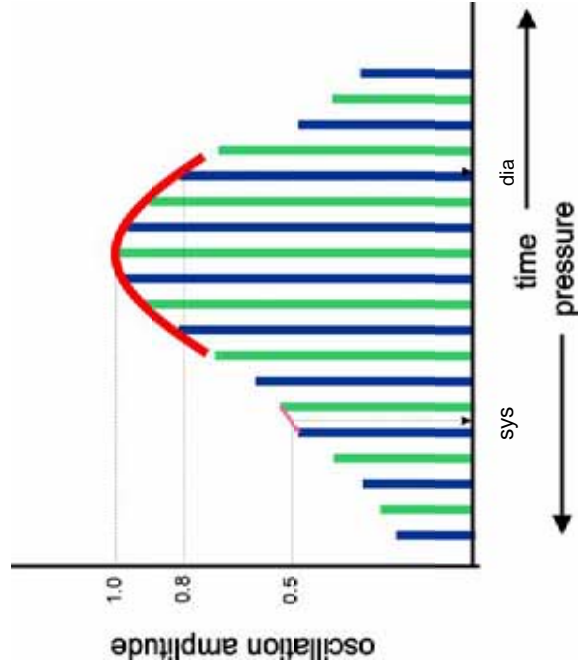

Fig.: Oscillometric principle

# Design of simulators

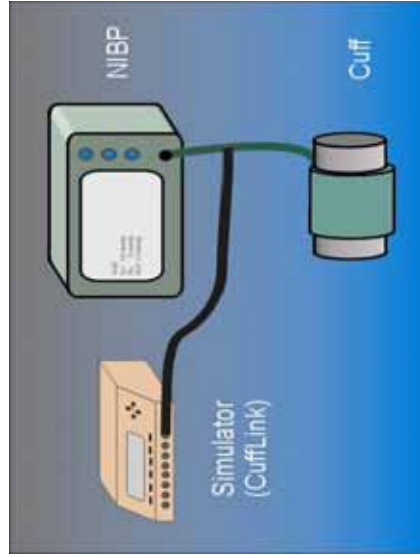

Fig.: the signal generator

CuffLink: SYS / DIA: 120 / 80 mmHg, HR: 80 1/min

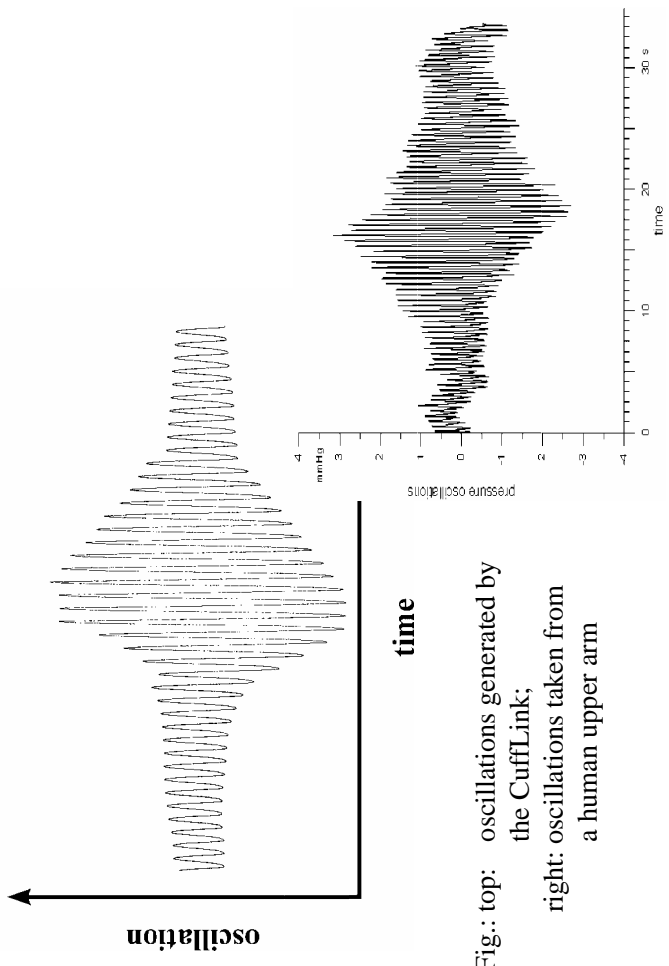
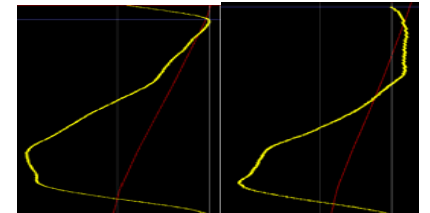
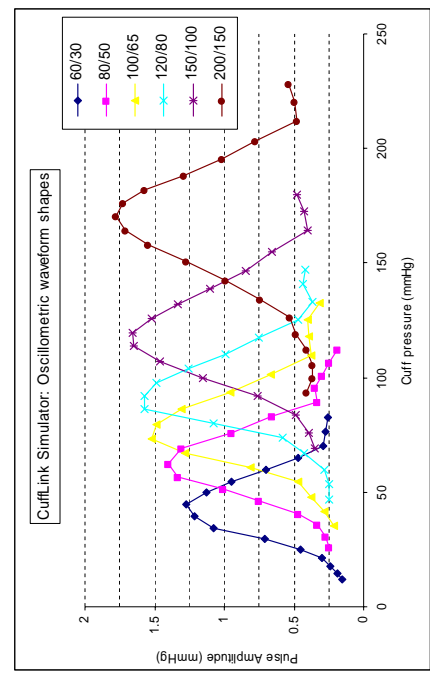

Fig.: top: oscillations generated by the CuffLink;  
right: oscillations taken from a human upper arm



## Artificial waveform Most commercial simulators

- Waveform smooth and shape unchanged with pressure
- Pulse shape doesn't change between systole and diastole



## Measurements performed with the CuffLink

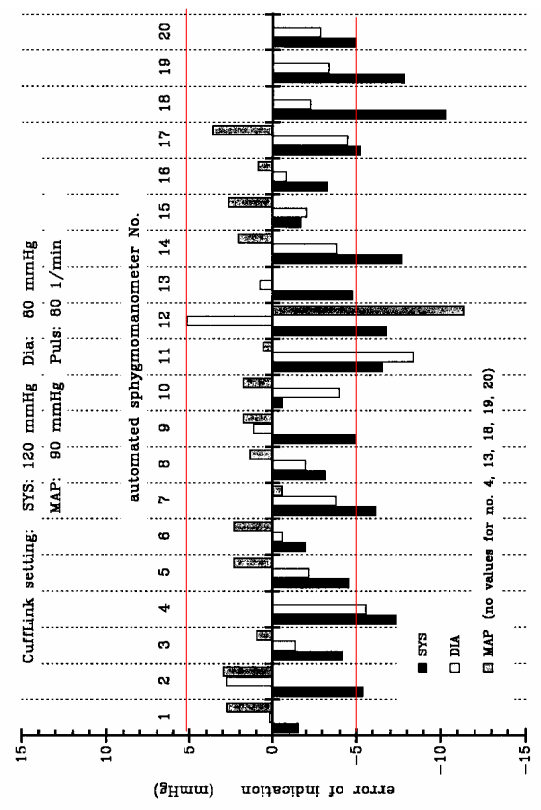

## Measurements performed with the CuffLink

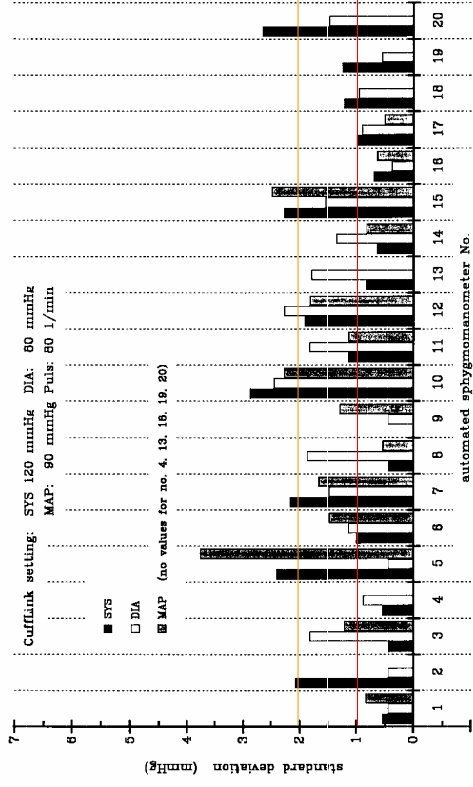

## Consequence

Conventional simulators like Cufflink, Smartarm, BP-Pump are

- unable to test accuracy
- but
- able to test repeatability and reproducibility

## Consequence

- Concept of the EU simulator:
- collection of oscillations from human subjects (with a separate device, i.e. recording unit)
  - database of human oscillograms
  - simulation of recorded oscillation
  - additional simulation of artefacts

## Data collection with recording unit



Fig.: Blood pressure measurement taken by two independent observers using a dual-headed stethoscope

58

Software to process the signals for simulation

Fig.: Data segmentation

Software to process the signals for simulation

Software to process the signals for simulation

EU simulator:  
Principle

## EU simulator: Pressure Pulse Generator



## EU simulator: Pressure Pulse Generator

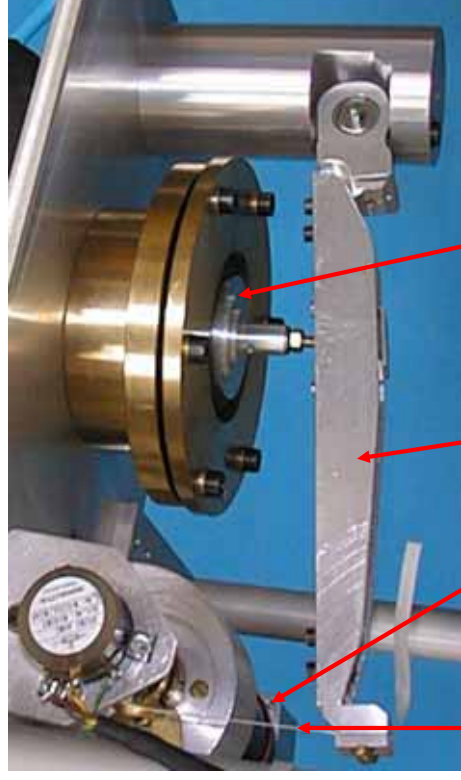

tape motor lever diaphragm

## EU simulator: Pressure Pulse Generator

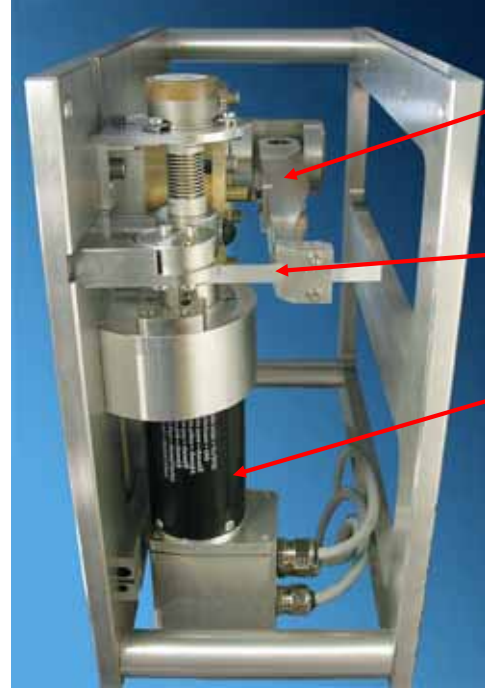

motor tape lever

## EU simulator: Pressure Pulse Generator



## Physiological Waveform

A few specialised simulators

- Oscillometric waveform varies between individuals
- Pulse shape varies between systole and diastole

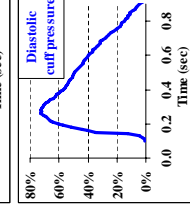
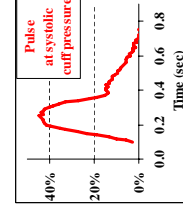
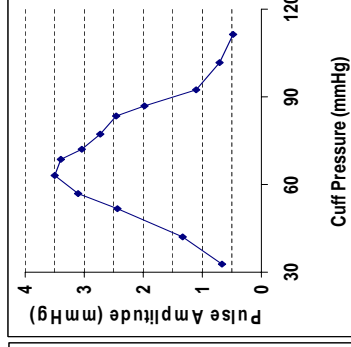
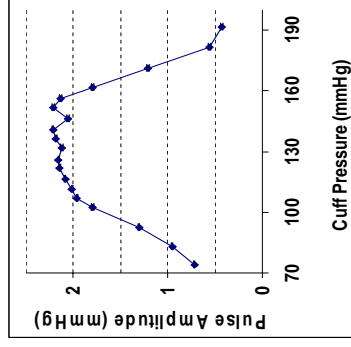

# Physiological Simulator evaluation

## Structure

- Accuracy requirements
- Why simulators ?
- Design of simulators
- **Results from measurements with simulators**
- **Outlook**

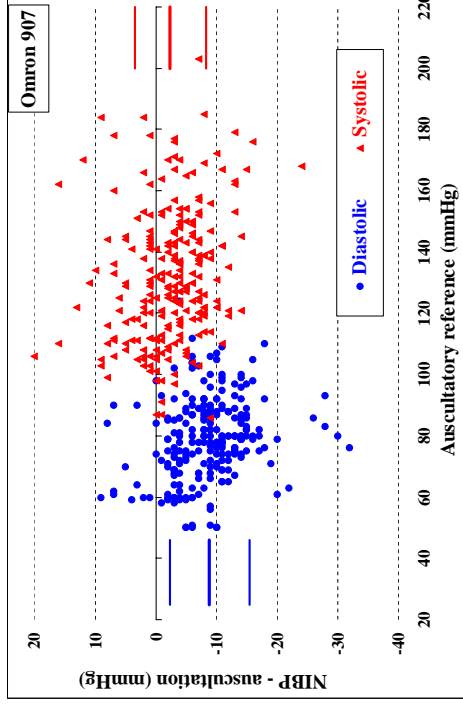

Amoore et al, Blood Pressure Monitoring, 2006, 11: 63-67

## Types of oscillometric waveforms

Affect: Systematic error, Consistency

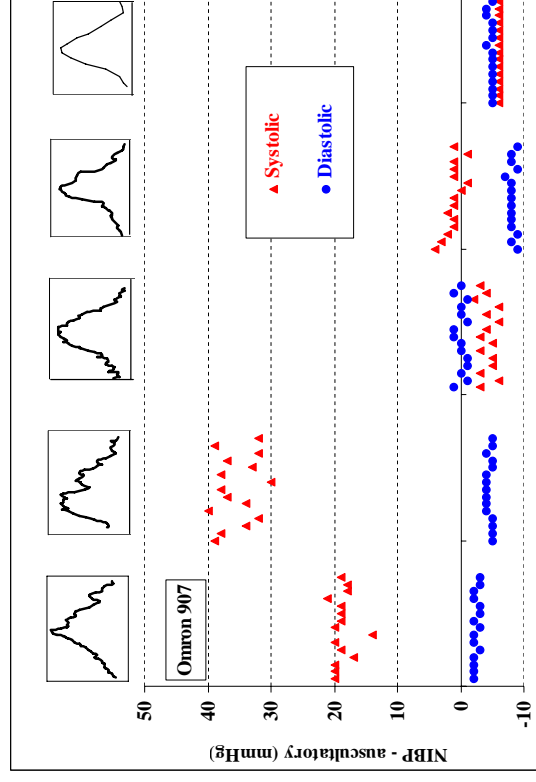

Murray I et al, in preparation

## Structure

- Accuracy requirements
- Why simulators ?
- Design of simulators
- Results from measurements with simulators
- **Outlook**



## **Promise of simulator validation:**

Consistent, reliable, comprehensive validation of BP devices

### Simulator requirements

- Technical: Accurate regeneration of oscillometric pulses
- Waveform sets: Comprehensive database of oscillometric waveforms – sets of pulses and associated cuff pressures
- Specialised conditions: Specialised patient conditions
- For developers: Sets of waveforms available for developers
- For validation centres: Separate sets for device validation?

## **Can simulator evaluation replace clinical study validation?**

Yes: Initial works suggests that it can, provided

- a. Sufficient waveforms
- b. Waveforms of specialised conditions
- c. Protocol developed and approved

Improve: Can simulator evaluation offer benefits?

- a. Better understanding of oscillometric technique
- b. Specialised conditions
- c. More than simply replicate clinical protocol

## **Towards the ideal simulator**

### Requires

- Comprehensive database of waveforms
- Validation protocol that assesses accuracy over comprehensive range of conditions
- Independent verification of the simulator

### Promises

- Better understanding of oscillometric waveform

## APEC/APLPMF Training Courses in Legal Metrology (CTI-11/2006T)

### Seminar on Automated Sphygmomanometers

#### Current situation in Germany for Sphygmomanometers



Stephan Mieke  
Physikalisch-Technische Bundesanstalt  
Berlin

### European Directives

The council of the European Community prepared three directives on medical devices:

- Council Directive 90/385/EEC of 20 June 1990 concerning *active implantable medical devices (AIMD)*
- Council Directive 93/42/EEC of 14 June 1993 concerning *medical devices (MDD)*
- European Parliament and Council Directive 98/79/EC of 27 October 1998 on *in vitro diagnostic medical devices (IVD)*

These directives have been implemented into the national legislation of each EU member state.

Electric or electronic medical devices bearing the CE-mark must also take into account other EC directives, when appropriate, e.g. the Council Directive 89/336/EEC of 3 May 1989 on the approximation of the laws of the Member States relating to electromagnetic compatibility.

- \* Austria (1995)
- \* Belgium (1952/58)
- \* Cyprus (2004)
- \* Czech Republic (2004)
- \* Denmark (1973)
- \* Estonia (2004)
- \* Finland (1995)
- \* France (1952/58)
- \* Germany (1952/58)
- \* Greece (1981)
- \* Hungary (2004)
- \* Ireland (1973)
- \* Italy (1952/58)
- \* Latvia (2004)
- \* Lithuania (2004)
- \* Luxembourg (1952/58)
- \* Malta (2004)
- \* The Netherlands (1952/58)
- \* Poland (2004)
- \* Portugal (1986)
- \* Slovakia (2004)
- \* Slovenia (2004)
- \* Spain (1986)
- \* Sweden (1995)
- \* United Kingdom (1973)

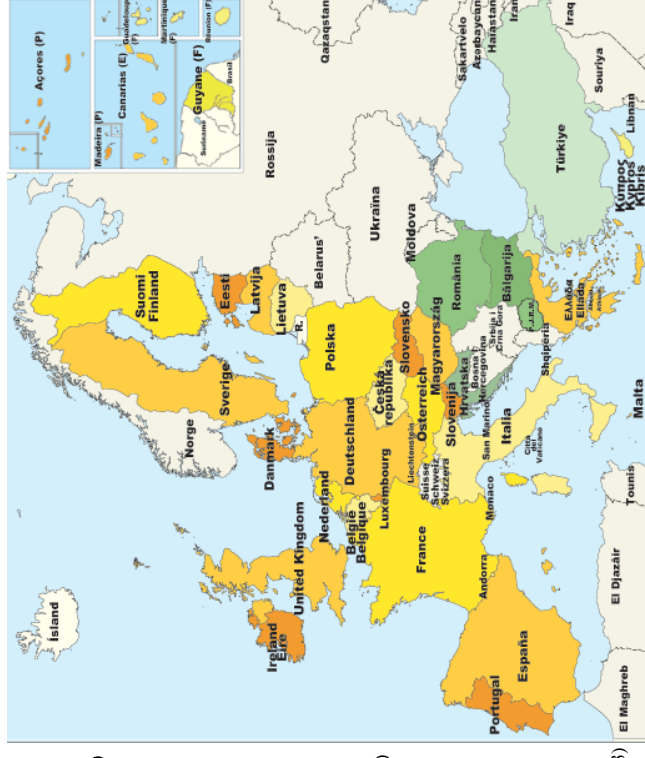

Declaration of conformity with the

## Medical Device Directive

allows to enter the European market



for medical devices with a measuring function: + ID-number of Notified Body!

## Basic steps to compliance

Determine whether the product is a medical device and complies with the MDD



↑ intended purpose / use

Determine whether the product is a medical device and complies with the MDD

### *Article 1*

#### **Definitions, scope**

(g) 'intended purpose' means the use for which the device is intended according to the **data supplied by the manufacturer** on the labelling, in the **instructions** and/or in **promotional materials**;

## Classification of the medical device

18 rules for:

1. non-invasive devices
2. invasive devices
3. active devices
4. ....

determine to which class a medical device belongs:

**Class I**

**Class IIa**

**Class IIb**

**Class III**

# Classification of the medical device

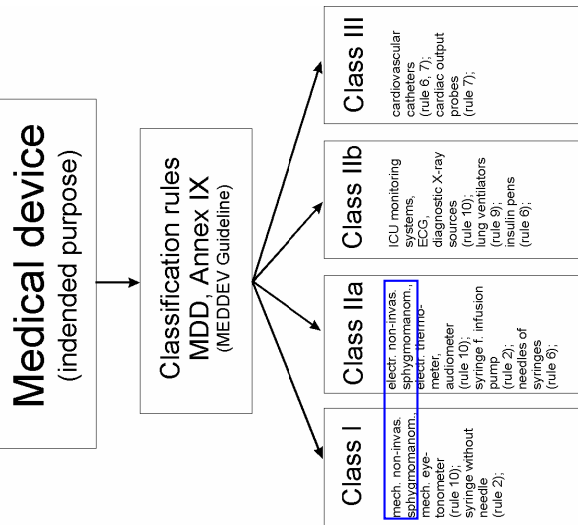

# ACTIVE DEVICES

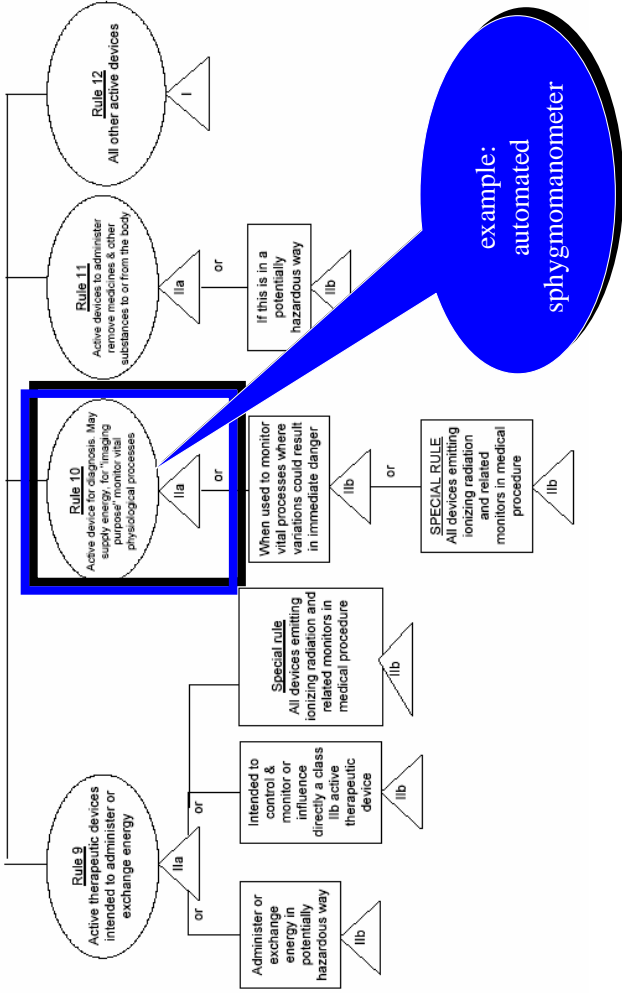

# conformity assessment routes

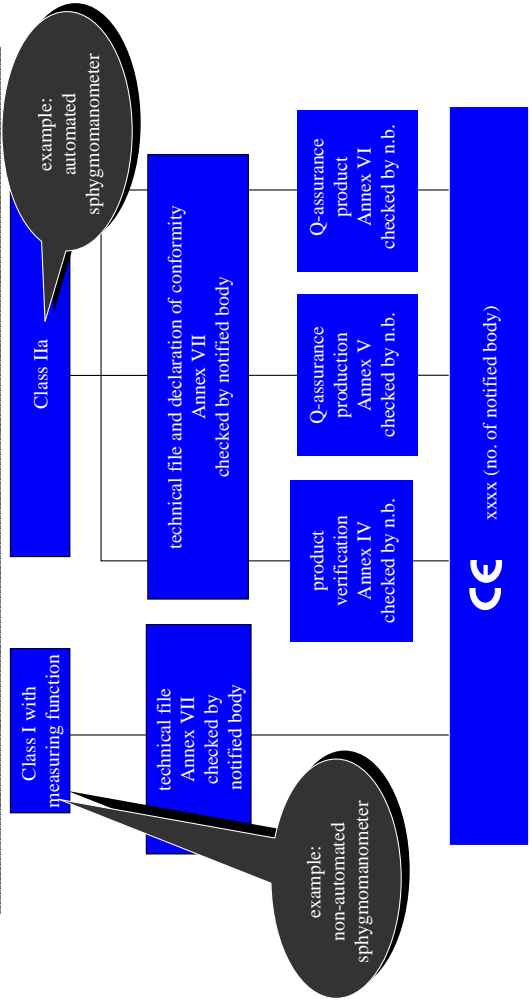

## 10. Devices with a measuring function

10.1. Devices with a measuring function must be designed and manufactured in such a way as to provide **sufficient accuracy and stability** within appropriate limits of accuracy and taking account of the intended purpose of the device.

**The limits of accuracy must be indicated by the manufacturer.**

10.2. The measurement, monitoring and display scale must be designed in line with **ergonomic principles**, taking account of the intended purpose of the device.

10.3. The measurements made by devices with a measuring function must be expressed in **legal units** conforming to the provisions of Council Directive 80/181/EEC ()

## Harmonized Standards



Not mandatory but compliance assumed, e.g. EN 1060

## More paperwork

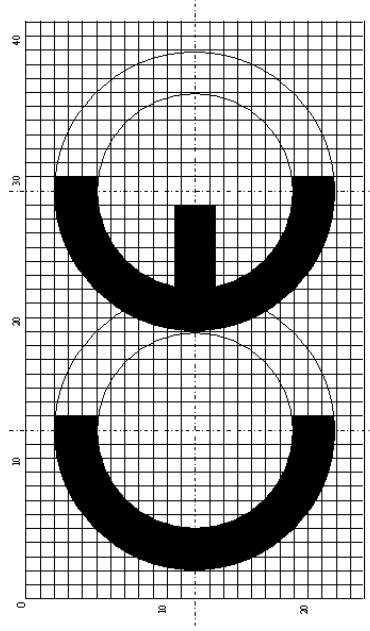
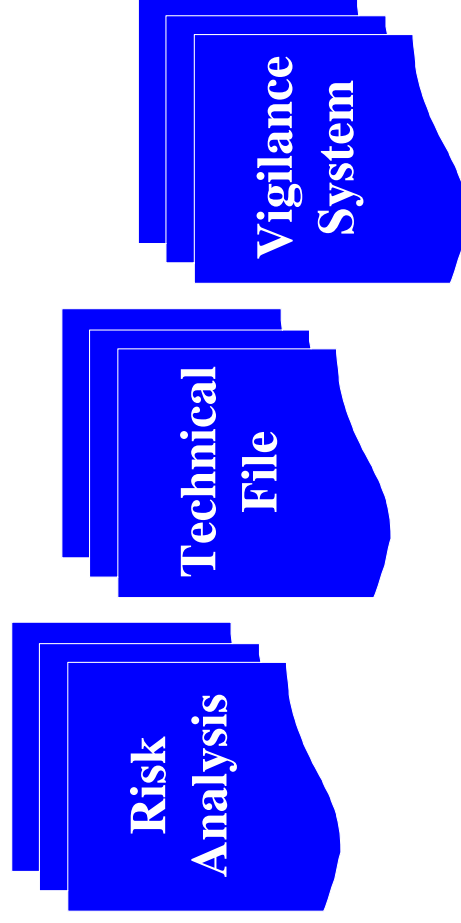



## After sale: national regulations are possible

*Germany:*

*Ordinance on the installation, operation and use of medical devices:*

It regulates the installation, operation and use of medical devices **after sale** and is **addressed to the user**, not to the manufacturer.



**Metrological Check**  
e.g. sphygmomanometer every 2y

## Metrological check for sphygmomanometer

**What is checked?**

- cuff pressure accuracy
- air leakage
- for Hg devices: stopping devices at tube and reservoir
- ~~aneroid devices: hysteresis~~
- functional test

**Who is checking?**

Anybody, who has the know-how, the equipment and is independent from commercial interests, e.g. repair.

## Metrological check for sphygmomanometer

**Which equipment is required?**

- calibrated reference manometer with an error less than 0,8 mmHg (0,1 kPa),
- stop watch with an error less than 0,1s,
- ball (hand) pump with a deflation valve,
- rigid metal vessel with a capacity of 500 ml  $\pm$  5 % (upper arm device) or 100 ml  $\pm$  5 % (neonatal or wrist device),
- rigid cylinder for cuff, T-piece connectors and hoses,
- for Hg manometer: collecting vessel of adequate size,
- optional: simulator for automated sphygmomanometer

## Type approval system for Sphygmomanometers in Legal metrology, Japan

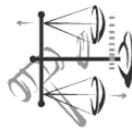

Shinichi BUNRYO  
National Metrology Institute of Japan (NMIJ)  
s.bunryou@nist.go.jp

<http://www.aist.go.jp> 産業技術総合研究所



Kilogram

## Chronological table 1 / 2

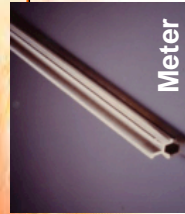

Meter

- 1875 the Metric Convention was concluded
- 1885 Japan joined the Metric Convention
- 1890 The prototypes of Meter and Kilogram were arrived at Japan
- 1891 1<sup>st</sup> Japanese Measurement law was promulgated (enforced in 1893)
- 1903 First National Research Laboratory of Metrology was established
- 1951 2nd Japanese Measurement law was promulgated (enforced in 1952)
- 1955 International Organization of Legal Metrology (OIML) was established
- 1959 Law amended
- 1961 Japan joined OIML
- National Research Laboratory of Metrology was established**
- 1966 Law amended

<http://www.aist.go.jp> 産業技術総合研究所

## Summary

- Introduction of Measurement law in Japan
- Chronological table
- Structure of Legal system
- Why need passing the Verification ?
- Restriction on transfer
- How pass Verification and Why need Type approval ?
- Criteria for Qualification of Verification
- Technical requirements for Type approval

<http://www.aist.go.jp> 産業技術総合研究所

## Chronological table 2 / 2

- 1980 Type approval system for Sphygmomanometers started**  
(Ordinance of the Ministry of Economy, Trade and Industry (METI) was amended)
- 1992 Present Japanese Measurement law was promulgated (enforced in 1993)
- 1994 APLMF was established
- 1999 Law amended
- 2001 OIML R16 Edition 2002 was approved for final publication by the International Committee of Legal Metrology (was submitted to the International Conference of Legal Metrology in 2004 for formal sanction)
- National Institute of Advanced Industrial Science and Technology (AIST) was established (remodeled) from  
National Research Laboratory of Metrology  
under the former Agency of Industrial Science and Technology
- 2005 JIS T1115 was amended as Non-invasive Automated Sphygmomanometers based on OIML R16-2.
- Ordinance of the Ministry of Economy, Trade and Industry (METI) was amended  
**MITI in 2001**

<http://www.aist.go.jp> 産業技術総合研究所



# Structure of Legal system

## Primary objective

Contribute to economic development and cultural enhancement

## Secondary objectives

Ensure appropriate implementation of measurement

Establish standards for measurement

Provision of accurate measuring instruments

Provision of measurement standards

Uniformity of units

Implementation of appropriate measurement

Promotion of autonomous measurement administration

Accurate and fair execution of the law

## Policies

<http://www.aist.go.jp>



# Policies and Task 1/2 Task

## Policies

Uniformity of units

Conformity of measurement units with International System of Units (SI units)

Prohibition of use with non-legal measurement units

Provision of measurement standards

Calibration of measuring instruments, system of Accredited Calibration Laboratories (JCSS) NITE

Notification of business relating to measuring instruments

Restriction for transfer of special specified measuring instrument

System of special bottles

Provision of accurate measuring instruments

Verifications

System of designated manufacturers

Inspection of verification standards

<http://www.aist.go.jp>



# Policies and Task 2/2

## Policies

Implementation of appropriate measurement

Obligation to measure accurately

Measurement relating to sale of Commodities

Restriction on Use

Periodic inspection

Registration of measurement certification business

Inspection for measurement certification

Collection of reports, spot inspections

Certified measurers

Proper measurement control business place

<http://www.aist.go.jp>



# Description on the Law about measuring Units



(Measuring Units relating to the International System of Units)  
**Article 3**

The measuring units of the quantities of the state of physical phenomena enumerated in the left column of Table 1 among the quantities of the state of physical phenomena enumerated in Paragraph 1 Item (1) of the preceding Article shall be those listed in the right column of the same Table and **the definition of each of those units shall be prescribed by Cabinet Order in accordance with resolutions of the International Conference of Legal Metrology and other international resolutions and practices with regard to measuring units.**



(Prohibition of the Use of Non-Legal Measuring Units)  
**Article 8**

**Non-legal measurement units** shall not be used for the purpose of transaction or certification

(Measuring Instruments Graduated with Non-Legal Measuring Units)  
**Article 9**

Graduated or marked with **non-legal measurement units** shall not be sold or exposed for sale.

<http://www.aist.go.jp>





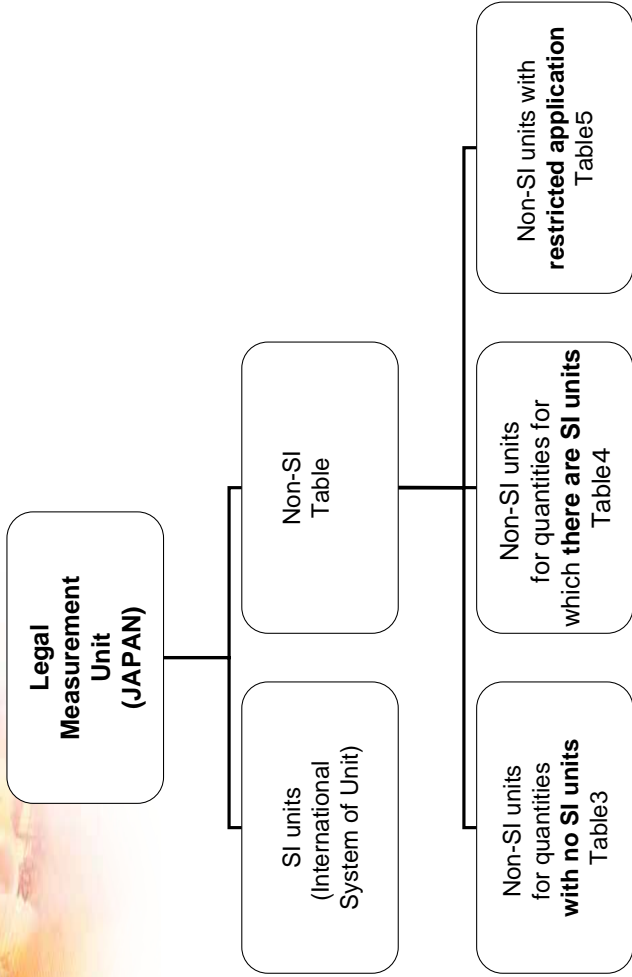

## What's "Specified measuring instrument?"

1/2

### (Definition, etc.) Article 2



The term "measuring instrument" as used in this Law shall mean appliances, machines or equipment used for measurements and the term "**Specified measuring instruments**" shall mean measuring instruments used in transaction or certification, or supplied mainly for the life of normal consumers and specified by Cabinet Order as those for which standards shall be standardized their structure and error in order to ensure proper measurements.

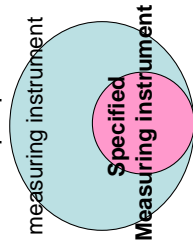

## Relationship between National Standard Provision Scheme and Calibration Laboratory Accreditation Scheme under JCSS

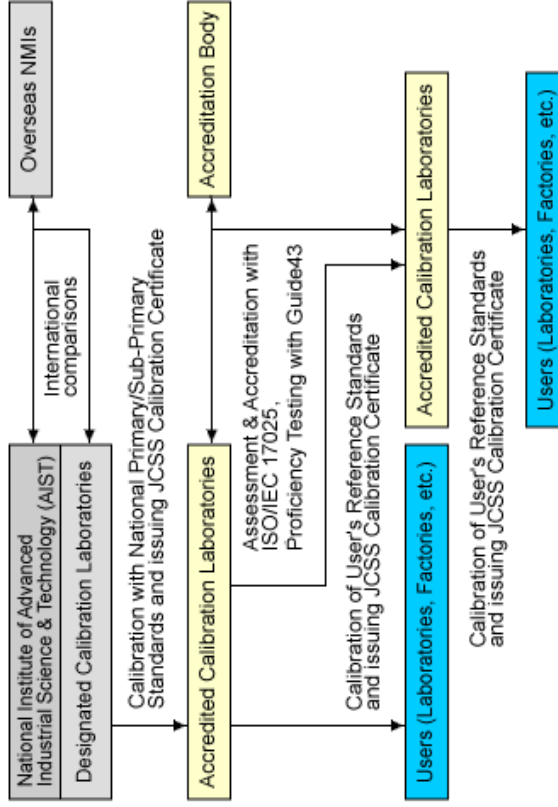

<http://www.nite.go.jp/asse/jcss/en/std/index.html>

## What's "Specified measuring instrument?"

2/2

(Specified Measuring Instrument)

Article 2 Cabinet Order

Specified measuring instrument	
1. Taxi meters	10. Calorimeters
2. Weight meter	11. Maximum demand energy meters
3. Thermometers	12. Watt meters
4. Measuring machines of leather area	13. Reactive power meters
5. Volume meters	14. Illuminometers
6. Flow velocity meters	15. Noise meters
7. Density hydrometers	16. Vibration level meters
8. Aneroid manometers Aneroid Sphygmomanometer	17. Densitometers
9. Flow meters	18. Hydrometer-type density meters

## Restriction on Transfer

Clinical specified measuring instruments

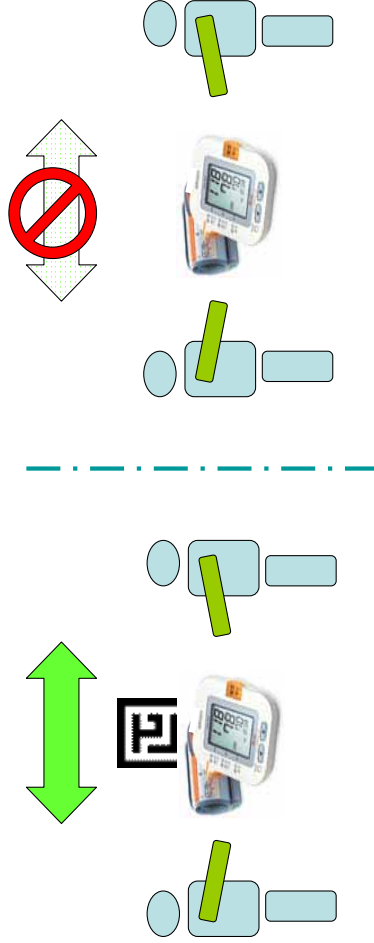

## Restriction on Transfer 1/2

Article 15 on Cabinet Order

- (1) Glass clinical thermometers
- (2) Clinical resistance thermometers
- (3) Aneroid Sphygmomanometer

(Restriction on Transfer, etc.)

Article 57

1. Any person engaged in the business of manufacture, repair or import of clinical thermometers and other specified measuring instruments prescribed by Cabinet Order shall not transfer or lend such specified measuring instruments to anyone, or deliver them to those who undertake the repair thereof, unless those specified measuring instruments are affixed the verification mark or Designated manufacturer Mark

## Restriction on Transfer 2/2

(Restriction on Transfer, etc.)

Article 57

2. Any person engaged in the business of sale of specified measuring instruments prescribed by Cabinet Order as mentioned in the preceding paragraph (excluding those defined in the preceding paragraph) shall not transfer, lend, or possess for the purpose of transferring or lending the specified measuring instruments unless those specified measuring instruments are affixed the verification mark or Designated manufacturer Mark ...



(Restrictions on Use)

Article 16

1. Any of the following items shall not be used or possessed for use with the purpose of measurements in legal measuring units when conducting of transactions or certification.
- (1) Non-measuring instruments
  - (2)



Page down

## Restriction on Use 2/3

(Restrictions on Use)

Article 16

(2) Specified measuring instruments besides of the following:

a) **Specified measuring instruments affixed the verification mark (Mark) in Article 72 Paragraph 1** certifying the passing of the verification by the Minister of Economy, Trade and Industry, or the prefecture governor, or Japan Electric Meters Inspection Corporation, or a person designated by the Minister of Economy, Trade and Industry

b)  [Page down](#)



Law

<http://www.aist.go.jp>

産業技術総合研究所

## Restriction on Use 3/3

(Restrictions on Use)

Article 16

(2) Specified measuring instruments besides of the following:

b) **Specified measuring instruments manufactured by manufacturers designated by the Minister of Economy, Trade and Industry and affixed the mark (Mark) mentioned in Article 96 Paragraph 1**



Law

<http://www.aist.go.jp>

産業技術総合研究所

## Criteria for Qualification 1/2

– to pass Verification –

(Criteria for Qualification)

Article 71

1. A specified measuring instrument **pass the verification** inspection when it confirms **both of the following criteria**:

(1) The **structure** (including performance and material properties) **conforms to technical requirements** prescribed by Ordinance of the METI.

(2) The **instrumental error does not exceed the tolerance of the verification** prescribed by Ordinance the METI.



Law

<http://www.aist.go.jp>

産業技術総合研究所

## Criteria for Qualification 2/2

– to pass Verification –

(Criteria for Qualification)

Article 71

2. The conformity to the Preceding Paragraph Item (1) shall be determined in accordance with procedures prescribed by Ordinance the METI.... however, that in the case of verifying, **specified measuring instruments affixed with a declaration under Article 84 Paragraph 1, they shall be regarded as conforming to technical requirements...**



[Page up](#)



Article 71 1(1)

### Affix with Declaration 1/2 under Article 84 Paragraph 1



(Declaration) Article 84

1. When a manufacturer or an importer who has approved type has manufactured or imported a specified measuring instrument in types of which are approved as their products, they can, in accordance with Ordinance of the METI, **affix a declaration to the specified measuring instruments.**
- 2....
3. 

Page down

### If Affixed with Declaration nor

Specified measurement Affixed with Declaration

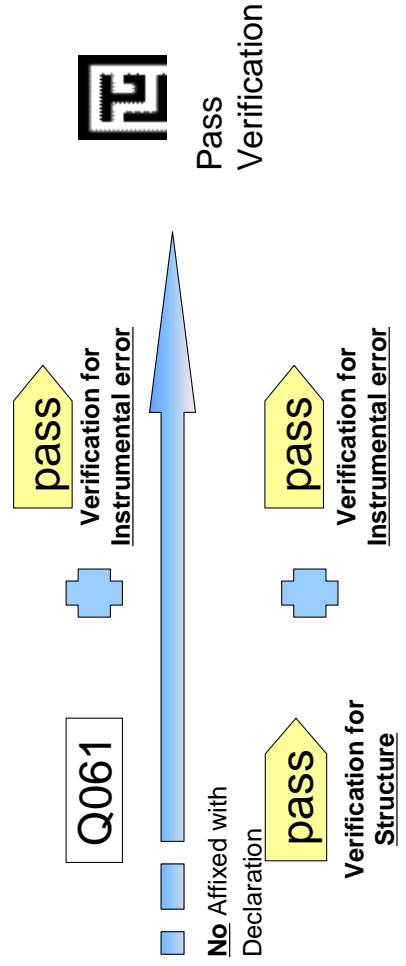

### Affix with Declaration 2/2 under Article 84 Paragraph 1

(Declaration) Article 84

3. Any person shall not affix to specified measuring instruments the same or a confusingly similar declaration to the declaration mentioned in Paragraph 1, except in the case provided for in the same Paragraph.

### Technical requirements for Type approval 1/2

#### Marking of the device ( R16-2 7.4)

- name and/or trademark of manufacturer
- serial number and year of fabrication
- measuring range and measuring unit
- type approval number

## Technical requirements for Type approval 2/2

### Metrological requirements

- Maximum permissible errors of the cuff pressure indication (R16-2 5.1)
- Environmental performance
- Storage (R16-2 5.3.1)
- Temperature, relative humidity (R16-2 5.3.2)
- Technical requirements for the display (R16-2 6.3)
- Digital indication (R16-2 6.8.2)
- Effect of voltage variations of the power source (R16-2 6.4)
- Internal electrical power source (R16-2 6.4.1)
- External electrical power source (R16-2 6.4.2)
- Pneumatic system (R16-2 6.5)
- Zero setting (R16-2 6.5.4)
- Electromagnetic compatibility (R16-2 6.6)
- Stability of the cuff pressure indication as pressure ( unique)

<http://www.aist.go.jp>



産業技術総合研究所

## Number of Approved Type of Sphygmomanometer in Japan

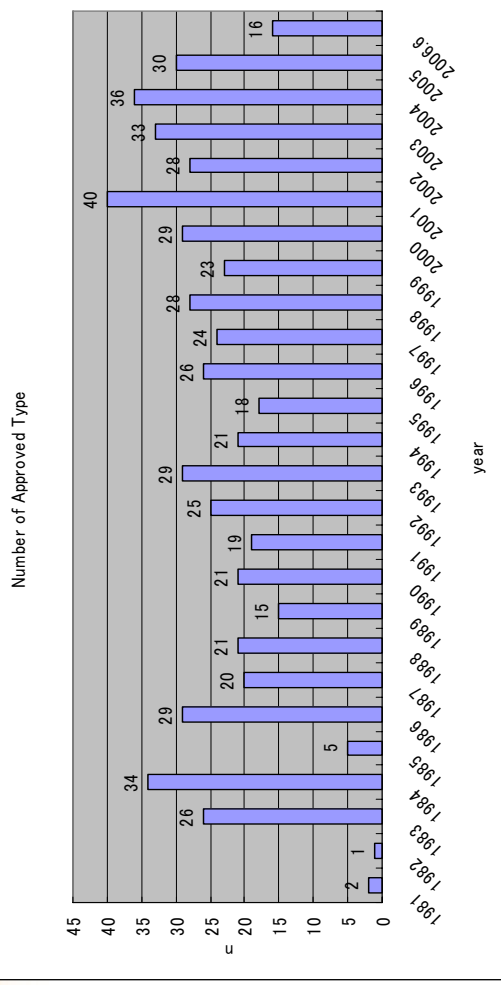

<http://www.aist.go.jp>



産業技術総合研究所

# Automated Sphygmomanometers

## Introduction

## Mode for Testing

Shinichi BUNRYO  
 National Metrology Institute of Japan (NMIJ)  
 s.bunryou@aist.go.jp



## Automated Sphygmomanometers



## Cuff

OIML R16-2

### 2. Terminology

- 2.1 **Bladder** Inflatable component of the cuff
- 2.3 **Cuff** Component of the sphygmomanometer, comprising a bladder and a sleeve, which is wrapped around the limb of the patient.
- 2.8 **Sleeve** Essentially inelastic part of the cuff that encloses the bladder



## Automated Sphygmomanometers



# Automated Sphygmomanometers (Patient Monitor)



<http://www.medrad.com/products/mr/veris-mr-monitor.html>

## Basic Components

1. Pneumatic system  
transducer, pump, valve, tube, connectors
2. PCB( with CPU)
3. Indication (Display)
4. Power supply
5. (Microphone for Auscultatory method only)



# Non Automated Sphygmomanometers (Electrical)



## Capacitance type pressure sensor

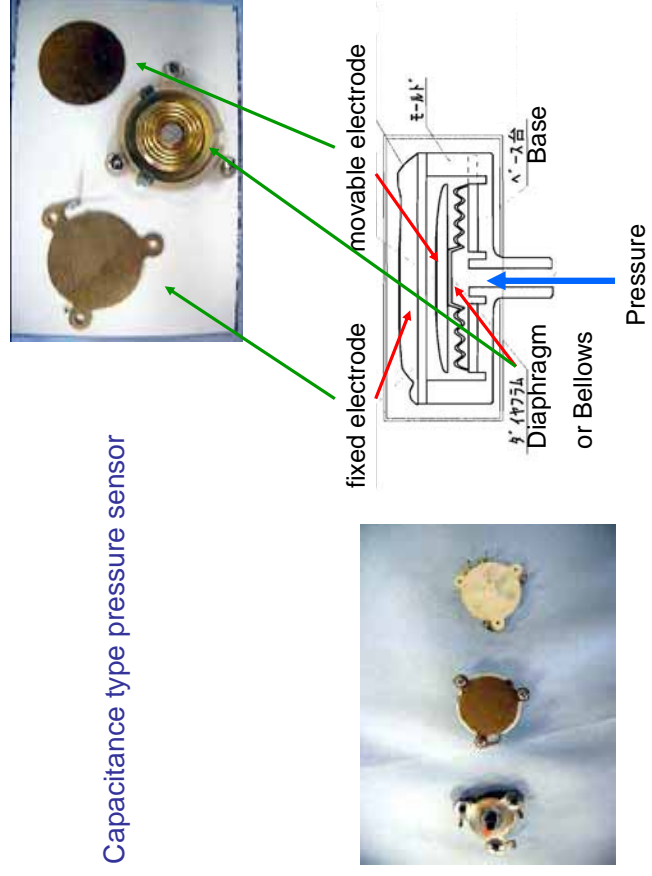

Basic Components

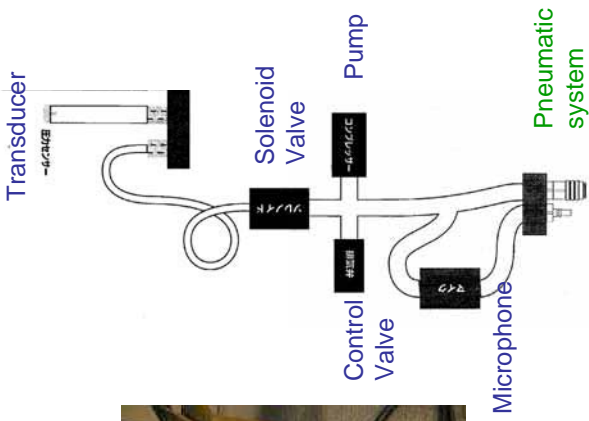

Basic Components

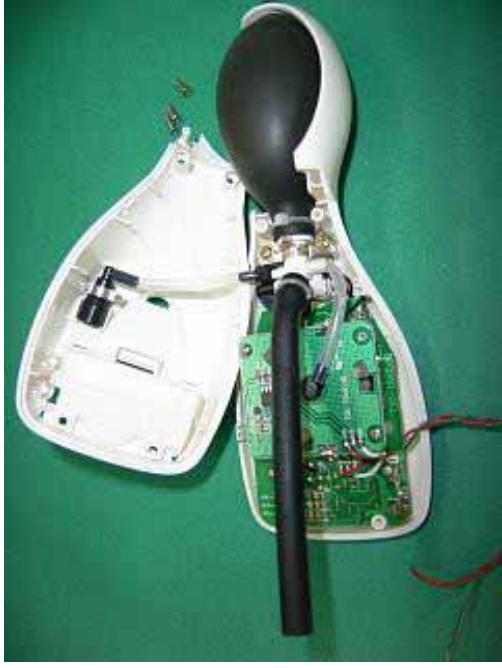

Mode for testing

Figure Annex A.2

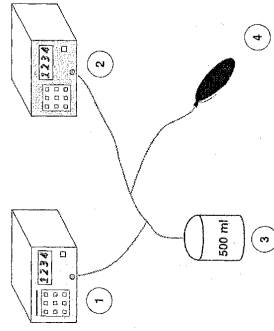

1. Reference manometer
2. Tested Sphygmomanometer
3. Metal vessel
4. Pressure generator

Metrological testing

Comparing as "pressure"  
**Feature of Measuring of NIBP**  
 Exhaust air for measuring of BP

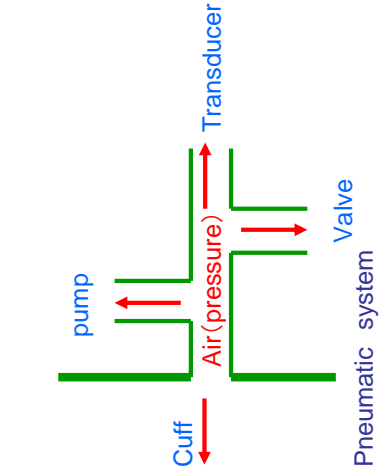

Mode for testing

Particular tools

Particular plug

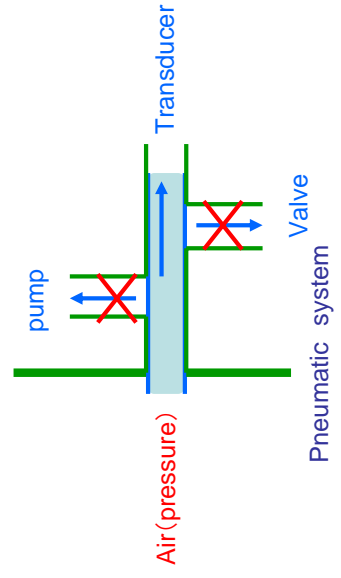



## Mode for testing with particular plugs



particular plugs



## Basic connection for testing

Figure of Annex A.2

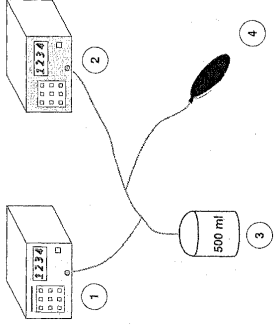

1. Reference manometer
2. Tested Sphygmomanometer
3. Metal vessel
4. Pressure generator



## Mode for testing

Directly connecting  
to pressure sensor



# WELCOME TO ETC

## APLMF Seminar

APLMF Executive Secretary- Dr. Tsuyoshi Matsumoto

太平洋法定計量事務局長

PTB - Dr. Stephan Mieke

德國聯邦物理技術研究院(PTB)專家

NMIJ- Mr. Shinichi Bunryou

日本國家計量機構(NMIJ)專家

經濟部標準檢驗局(BSMI) - 陳副組長 武雄先生

國內業者先進

## 行程 Agenda

Time(20 <sup>th</sup> , July)	活動內容 Content
8 : 50	抵達 Arrive ETC
8 : 50 – 9:00	王執行長致歡迎詞 Welcome speech by President Wang
9 : 00 – 9:20	ETC公司簡介 Brief introduction of ETC
9 : 20 – 10:00	OIML R 16-2測試簡介 (性能、安規、EMC) OIML R 16-2 test items review
10 : 00 – 10:20	ETC實驗室參觀 Laboratory brief tour
10 : 20 – 11:00	性能、安規測試展示及問題與討論 Test demonstration and opinion exchange
11:00	結束close

## Background

**ETC, Since 1983, the ETC was previously one division of Electronics Research and Service Organization (ERSO) of ITRI. In 1983, the Ministry of Economic Affairs, Industrial Technology Research Institute, Taiwan Electrical and Electronic Manufacturer's Association, and public enterprises collectively promoted the establishment of the ETC.**



## ETC Brief

Porson Fu

Medical Equipment Group of

Product Safety Testing Department, Taiwan

## Primary Objectives

The ETC was founded to provide product inspection and registration services, as well as aid in the development of quality control and inspection technology. In addition, the ETC strives to improve local product quality and prosperity in the industry, and fight for the public benefit.



## Organization Chart

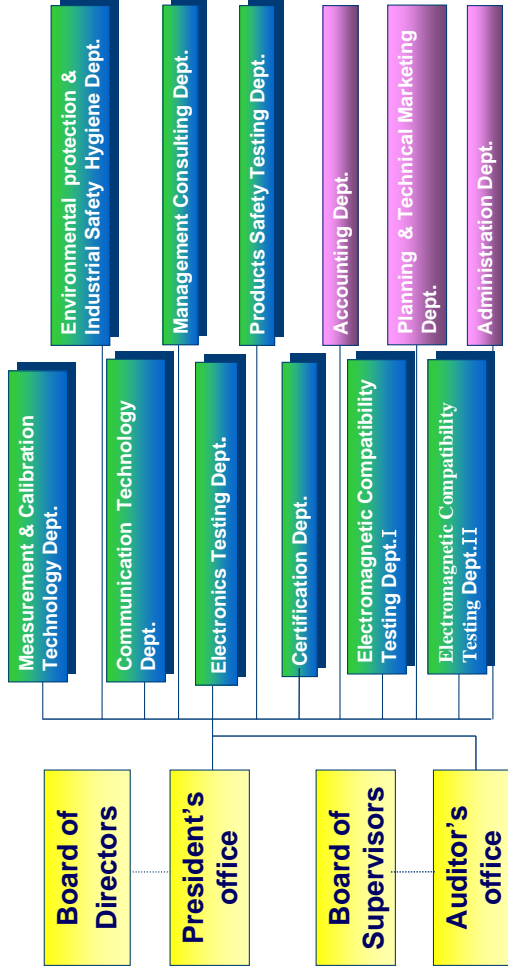

## Quality Policy

To pursue excellence in service quality with a dedicated working attitude.



## Number of Employees in Past Years

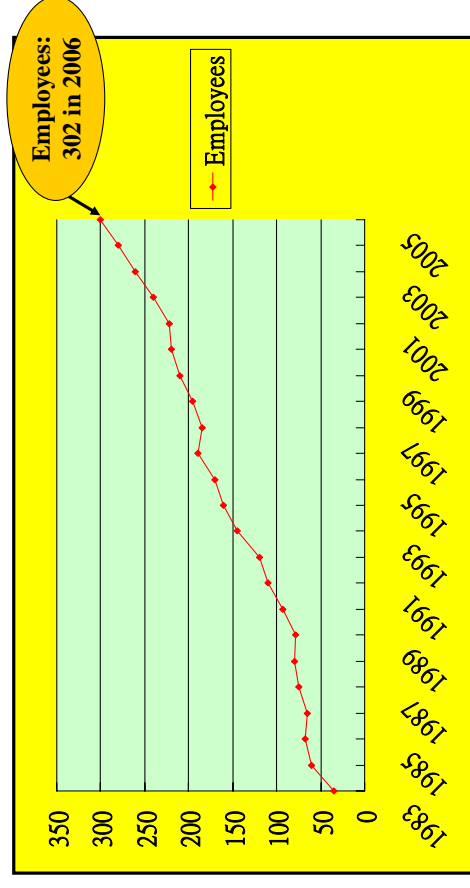

## Primary Services(1)

- Product Testing Services
- Product Safety Tests
- EMC Tests
- Function & Reliability Tests
- Testing and Verification of Telecommunication Terminal Equipment
- Environmental Label / Energy Efficiency Tests
- Chemical Analysis for Restriction of Hazardous Substances (RoHS)
- Inspection and Type Testing of Legal Measuring Instruments

## Primary Services(2)

- Products Certification services
- Instrument and Equipment Calibration
- Consulting Service
- Quality Management System
- Environmental Management System
- Intellectual Property Rights Management System
- Training of Professional Technology

## Product Safety Tests

### ■ Testing Standard & Products

IEC 60065: AV Products  
 IEC 60335: Home Appliances  
 IEC 60950: IT Products  
 IEC 60958: Lighting  
 IEC 60601: Medical Electrical Equipment

IEC 60745: Electric Tools  
 IEC 60320: Power Cord Assembly  
 IEC 61058: Power Switch

### ■ Testing Fields

BSMI, GS, PSE, S, CE, UL, CSA, FIMKO, NEMKO, SEMKO, and DEMKO, CB etc.  
 Our safety testing lab has been approved by IECEE and been registered in their CBTL list.  
 We could issue CB reports on IEC 60065 & IEC 60950.

## Product Safety Tests



## Electromagnetic Compatibility (EMC) Tests

- **Products:**  
Medical Equipment(ME), IT, Wire & Wireless Communication, Multimedia, Home Appliances, Lighting, Power Tools, Low-Power/Frequency Devices
- **Testing Standards:**  
-EMI Testing (IEC 555-2/-3)  
-EMS Testing (IEC 801-2~-6, IEC 61000 )  
-SAR
- **Testing Fields:**  
-Domestic is Approved by BSMI and NCC  
- Foreign agencies including the FCC of America , the European Notified Bodies, C-Stick of Australia and the VCCI of Japan .  
- CB Reports

## Inspection and Type Testing of Legal Measuring Instruments

- **Inspection Items :**  
-Noise meters,  
-Radar Speed Detectors,  
-Vehicle Exhaust Analyzers,  
-Breath Alcohol Testers and Analyzers,  
-Illumination Photometers.
- **Type Testing Items :**  
Illumination Photometers, Electronic Scales, Taxi Fee Meters



## ETC As Accredited Product Certification Organization

- APEC MRA Accredited and Registered Telecommunication Terminal Equipment Certification Organization
- ROC TAF accredited Telecommunication Terminal Equipment Certification Organization
- National Communications Commission (NCC),
- Ministry of Transportation and Communications (MOTC) Accredited Telecommunication Terminal Equipment Certification Organization
- Product Certification Organization Approved by Hong Kong Special Administrative Region Electrical and Mechanical Services Department

## Certifications and Issuing Institutes

Our Testing Lab	Certificate Issuing Institution
Headquarters	ISO 9001 / BSMI & TÜV-SÜD
<u>Environmental Management Assistance Institute</u>	ISO 14001 / TÜV-SÜD
<u>Product Safety Laboratory</u>	Industrial Development Bureau, MOEA
	CBTL / IECEE
	NCC, TAF / Taiwan
	CNAL / China
	TÜV-SÜD , VDE / Germany
	FIMKO / Finland
	JOA / Japan

## Certifications and Issuing Institutes

Our Testing Lab	Certificate Issuing Institution
<u>EMC Testing Laboratory</u>	CBTL / IECCE
	BSMI, TAF, NCC / Taiwan
	TÜV-süd , TÜV-Rheinland / Germany
	FCC, NVLAP , UL / USA
	IC / Canada
	FIMKO / Finland
	NEMKO / Norway
	VCCI / Japan

## International Collaboration

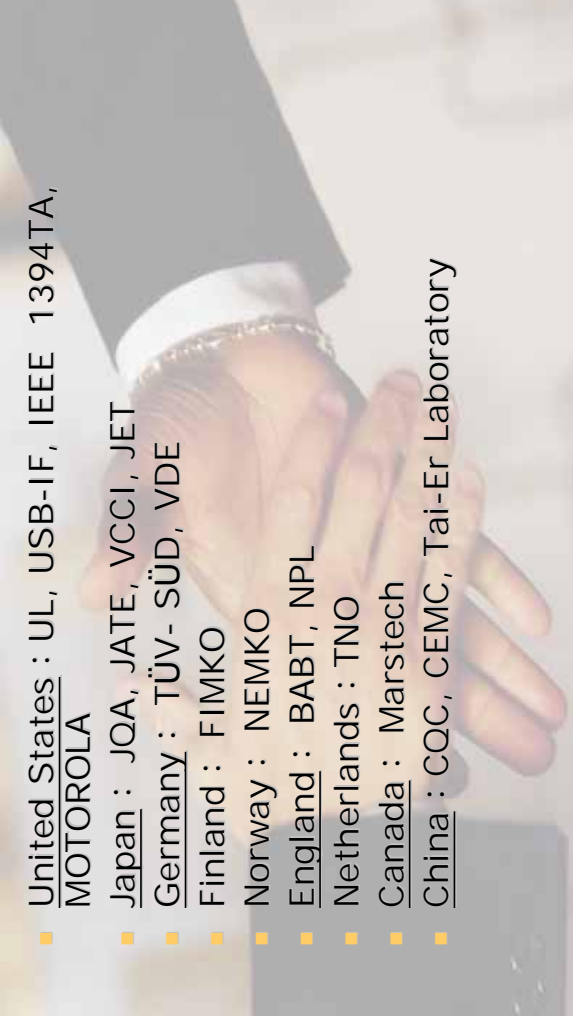

- United States : UL, USB-IF, IEEE 1394TA, MOTOROLA
- Japan : JOA, JATE, VCCI, JET
- Germany : TÜV- SÜD, VDE
- Finland : FIMKO
- Norway : NEMKO
- England : BABT, NPL
- Netherlands : TNO
- Canada : Marstech
- China : COC, CEMC, Tai-Er Laboratory

## Service Departments and Laboratories

- Headquarters (Taoyuan Guishan Linkou-Gong-San Industrial Park)
- Linkou Lab (Linkou Dingfu Village)
- Hsinchu Lab ( Hsinchu Science Park)
- Taichung Lab(Taichung Industrial Park)
- Tainan Lab (Anping Industrial Park)

## Non-invasive Automated Sphygmomanometers Type Testing

## NIBP Testing According to OIML R16-2

- Product Safety Testing? (IEC 60601-1:2005)
- EMC (ElectroMagnetic Compatibility) Testing (IEC 60601-1-2: 2001)
- Resistance to Vibration and Shock (OIML R16-2: 2002)
- NIBP Performance Testing (OIML R16-2: 2002)



## OIML R16-2: Safety

- 6.11 Safety
  - 6.11.1 Cuff pressure
    - It shall be possible to abort any blood pressure measurement at any time by single key operation and this shall lead to rapid exhaust.
  - 6.11.2 Unauthorized access
    - All controls that affect accuracy shall be sealed against unauthorized access.
  - 6.11.3 Tubing connectors
    - To avoid connecting the output of the blood pressure measuring device to such systems as air might inadvertently be pumped into a blood vessel. Luer lock connections shall not be used.
  - 6.11.4 Electrical safety
    - Electronic or automated sphygmomanometers shall comply with the relevant national safety regulations. → IEC 60601-1



## IEC 60601 Series: Medical Electrical Equipment

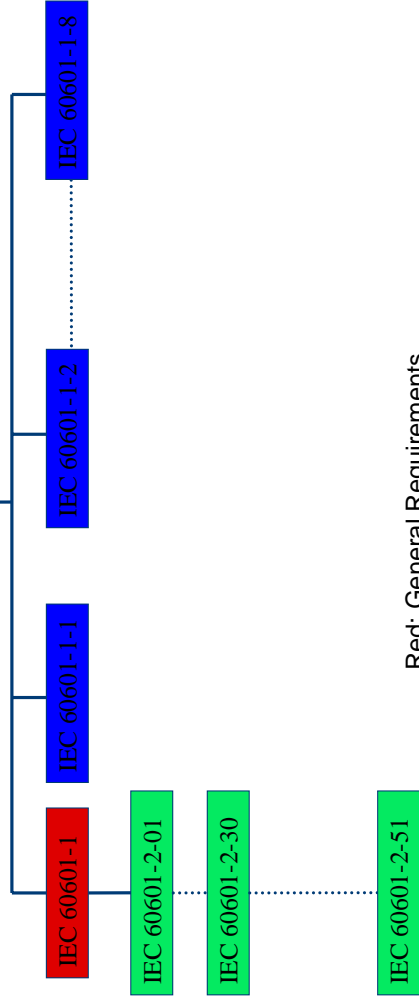

Red: General Requirements  
 Green: (perpendicular) Particular Requirements  
 Blue: (parallel) Collateral Standard

- ### IEC 60601 Series: Medical Electrical Equipment
- IEC 60601-1: General requirements for safety
  - IEC 60601-1-1-2: Electromagnetic compatibility requirement and test
  - IEC 60601-2-30: Automatic cycling non-invasive blood pressure monitoring equipment
  - IEC 60601-1-1: Safety requirements for medical systems
  - IEC 60601-1-4: Programmable electrical medical systems

## Non-invasive Automated Sphygmomanometers Testing



## IEC 60601-1: Classification(1)

- Classification of power source
  - Class I Equipment - Uses PE as 1 LOP.
  - Class I Equipment (also known as Double Insulated) - Does not use PE as 1 LOP.
- Internally powered equipment
- Definition applied parts: Part of me equipment that in normal use necessarily comes into physical contact with the patient
- Classification of applied parts: the degree of protection against electric shock B < BF < CF
- Type B Applied Part
- F-Type Isolated (Floating) Applied Part
  - Type BF Applied Part
  - Type CF Applied Part: Direct cardiac application

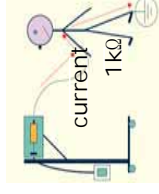

## F-Type (BF/CF) Applied parts

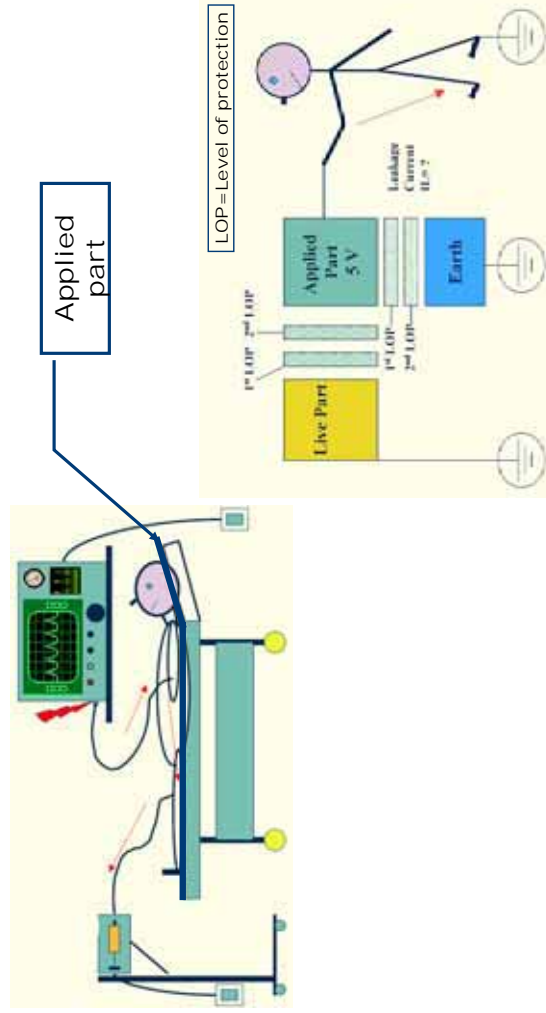

## IEC 60601-1: Classification(2)

- Classification of Equipment Operation Mode
  - Continuous Operation
  - Short-time Operation
  - Intermittent Operation
  - Continuous Operation with Short-time Loading
  - Continuous Operation with Intermittent Loading
- Classification of application with Flammable Anaesthetic Equipment not suitable for use with flammable anaesthetic
  - Category AP Equipment
  - Category APG Equipment
- Classification Against Ingress of Liquids
  - Drip-proof Equipment IPX1
  - Splash-proof Equipment IPX4
  - Watertight Equipment IPX7



## IEC 60601-1: Hazards

- Protection against electric shock hazards
- Protection against mechanical hazards
- Protection against excessive radiation
- Protection against flammable anaesthetic hazard
- Protection against excessive temperatures
- Protection against fire hazards
- Protection against abnormal operation and fault hazards

## Structure

- Product Safety Testing
- > EMC (ElectroMagnetic Compatibility) Testing?
- Resistance to Vibration and Shock (OIML R16-2: 2002)
- NIBP Performance Testing

## OIML R16-2: EMC

- 6.6 Electromagnetic compatibility
  - Either
    - Electrical and/or electromagnetic interferences shall not lead to degradations in the cuff pressure indication or in the result of the blood pressure
  - Or
    - If electrical and/or electromagnetic interferences lead to an abnormality, the abnormality shall be clearly indicated and it shall be possible to restore normal operation within 30s after cessation of the electromagnetic disturbance.
- Testing shall comply with IEC 60601-1-2

## According to IEC 60601-1-2

- EMC = EMI (Interference) + EMS (Susceptibility)



## EMI Test Items

- RF emissions (comply with CISPR 11)
- Harmonic emissions (IEC 61000-3-2)
- Flicker emissions (IEC 61000-3-3)

## RF Emissions Testing site

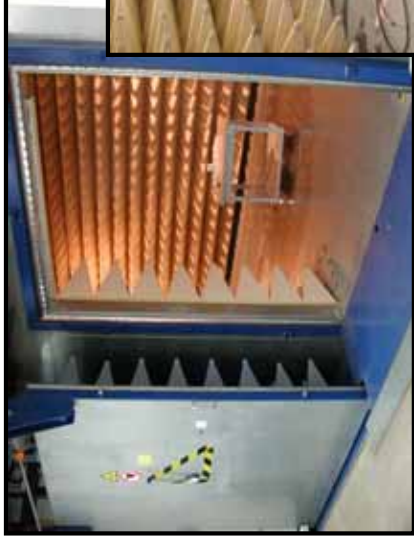

9m \* 6m \* 6m (EMI Semi-Anechoic Chamber)  
Testing shall be carried out in accordance with CISPR11

## EMS Test Items

- ESD (Electrostatic Discharge)
  - ±6 kV contact; ±8 kV air
- EFT (Electrical Fast Transient)
  - ±2 kV for power supply lines;
  - ±1 kV for input/output lines
- Surge
  - ±1 kV line to line; ±2 kV line to earth
- Voltage Dips
- Conducted RF immunity
- Radiated immunity

## EMS: Radiated Immunity

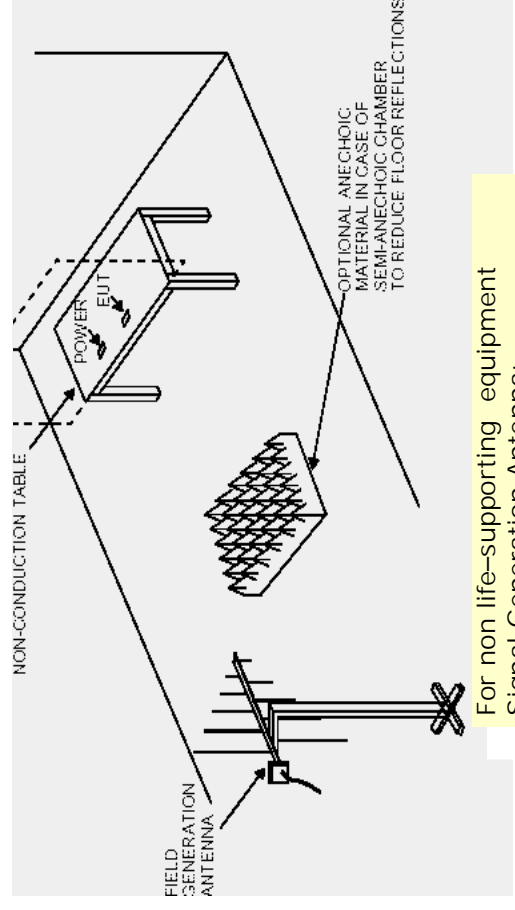

For non life-supporting equipment  
Signal Generation Antenna:  
Frequency = 80 MHz ~ 2.5 GHz  
Power = 3V/m

## Structure

- Product Safety Testing
- EMC(ElectroMagnetic Compatibility) Testing
- Resistance to Vibration and Shock (OIML R16-2: 2002)
- NIBP Performance Testing

## Resistance to Vibration and Shock

- 6.11.5
  - The sphygmomanometers shall comply with the relevant provisions of OIML D11:2004.

Note: After testing the device shall comply with the requirements of 5.1: Maximum permissible errors of the cuff pressure indication.

## Structure

- Product Safety Testing
- EMC(ElectroMagnetic Compatibility) Testing
- Resistance to Vibration and Shock (OIML R16-2: 2002)
- NIBP Performance Testing

## NIBP Performance Testing

- Maximum permissible errors of the cuff pressure indication
  - Error  $\leq \pm 3$  mmHg in the first time reading/50 mmHg a step
  - Error  $\leq \pm 4$  mmHg in use
- Apparatus
  - Rigid metal vessel 500 ml  $\pm 5\%$
  - Calibrated reference manometer with an uncertainty less than 0.8 mmHg
  - Pressure generator
  - T-piece connectors and hoses



## Effect of voltage variations of the power source

- Internal power supply regulation in steps of 0.1V
  - At the lowest voltage limit increased by 0.1V and also at the nominal voltage
  - Apparatus
    - Adjustable direct current voltage supply
    - Voltmeter with an uncertainty of less than 0.5% of the measured value
    - Calibrated reference manometer with an uncertainty of less than 0.8 mmHg
- Note: Add the high resolution DC power meter for monitoring voltage fluctuation



DC supply



DC power meter

## Zero setting

### Apparatus

- Rigid metal vessel 500 ml  $\pm$  5%
- Calibrated reference manometer with an uncertainty less than 0.8 mmHg
- Pressure generator
- T-piece connectors and hoses

### Procedure

- +106 mmHg
- 100 mmHg
- -94 mmHg

Inflation setting at

- +6 mmHg
- 0 mmHg
- -6 mmHg

Initiate zero setting at

100 mmHg

100 mmHg

100 mmHg

THANKS FOR YOUR  
ATTENTION

# Chang-Chyi Lin MD, PhD

- 1975-1982 MD; NDMC
- 1982-1986 Internal Medicine Residency
- 1986-1990 PhD; Duke University
- 1990-1992 Internal Medicine Residency
- 1992-1994 Cardiology Fellowship
- 1994-2005 Cardiology Attending; TSGH
- 2005- Cardiology Consultant; CSMC
- 1992- Associate Professor, Medicine



## NIBP monitor

-View from Cardiologist in practice

林昌琦

Chang-Chyi Lin MD, PhD

## What is BP

- Force of blood on arterial wall.

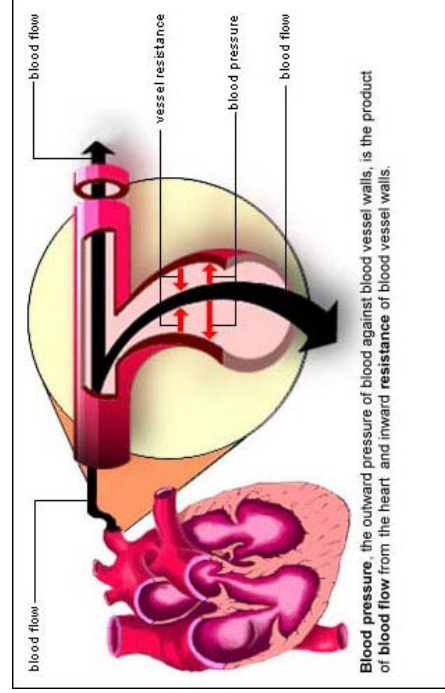

## BP patterns

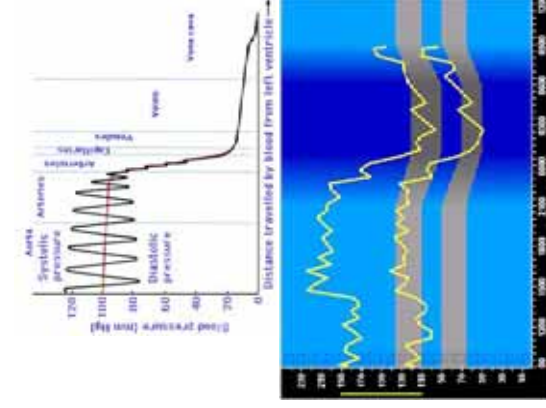

# What's regulating BP

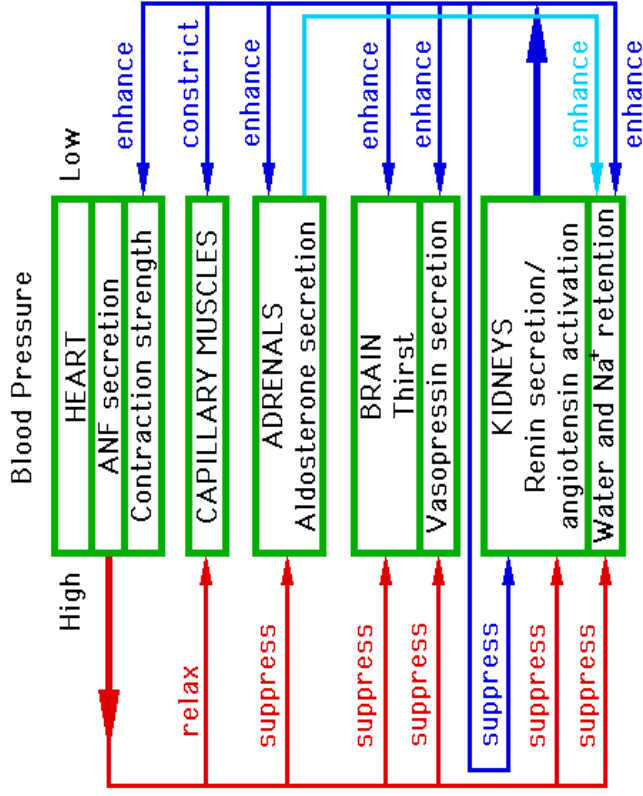

# Why BP is important

- BP is an important indicator for cardiovascular & overall health
- Routine task
  - Often carried out by the least trained, low priority
  - Less QC in equipment selection, calibration, repair, personnel training & performance evaluation



# Hypertension - the focus

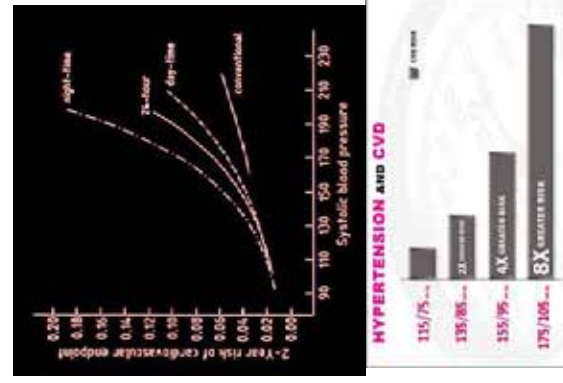
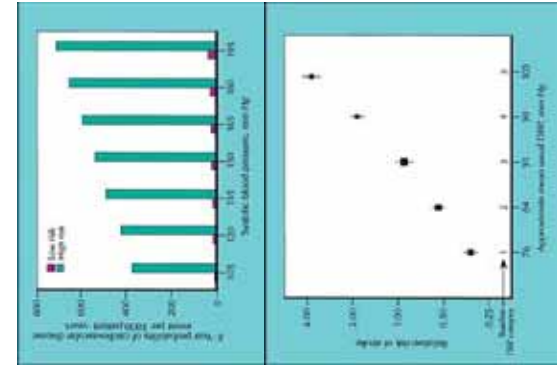

# JNC 7 Definition

BP Classification	SBP mmHg	DBP mmHg
Normal	<120	and <80
Prehypertension	120-139	or 80-89
Stage 1 Hypertension	140-159	or 90-99
Stage 2 Hypertension	≥160	or ≥100

## ESC Definition

Categories	Systolic BP mmHg	Diastolic BP mmHg
Proper BP	<120	<80
Normal	120-129	80-84
High Normal	130-139	85-89
Stage 1 Hypertension (Mild)	140-159	90-99
Stage 2 Hypertension (Moderate)	160-179	100-109
Stage 3 Hypertension (Severe)	≥180	≥110
Systolic Hypertension	≥140	<90

## CVD Risk

- HTN prevalence ~ 50 million people in the United States.
- The BP relationship to risk of CVD is continuous, consistent, and independent of other risk factors.
- Each increment of 20/10 mmHg doubles the risk of CVD across the entire BP range starting from 115/75 mmHg.
- Prehypertension signals the need for increased education to reduce BP in order to prevent hypertension.



## FAQ

- Does \*\*\* affect BP ?
  - Menopause: 5 mmHg systole
  - Smoking: temporary
  - Stress:
  - Obesity:
  - Coffee & sodas: temporary
  - Potassium: protection
  - Oral pills
  - HRT, sedatives, tranquilizers

## Benefit of BP control

Average Percent Reduction

- Stroke incidence 35–40%
- Myocardial infarction 20–25%
- Heart failure 50%

## BP Measurement Techniques

Method	Brief Description
In-office	Two readings, 5 minutes apart, sitting in chair. Confirm elevated reading in contralateral arm.
Ambulatory BP monitoring	Indicated for evaluation of “white-coat” HTN. Absence of 10–20% BP decrease during sleep may indicate increased CVD risk.
Self-measurement	Provides information on response to therapy. May help improve adherence to therapy and evaluate “white-coat” HTN.

## Office BP Measurement

- Use auscultatory method with a properly calibrated and validated instrument.
- Patient should be seated quietly for 5 minutes in a chair (not on an exam table), feet on the floor, and arm supported at heart level.
- Appropriate-sized cuff should be used to ensure accuracy.
- At least two measurements should be made.
- Clinicians should provide to patients, verbally and in writing, specific BP numbers and BP goals.

## Ambulatory BP Monitoring

- ABPM is warranted for evaluation of “white-coat” HTN in the absence of target organ injury.
- Ambulatory BP values are usually lower than clinic readings.
- Awake, individuals with hypertension have an average BP of >135/85 mmHg and during sleep >120/75 mmHg.
- BP drops by 10 to 20% during the night; if not, signals possible increased risk for cardiovascular events.

## Self-Measurement of BP

- Provides information on:
  1. Response to antihypertensive therapy
  2. Improving adherence with therapy
  3. Evaluating white-coat HTN
- Home measurement of >135/85 mmHg is generally considered to be hypertensive.
- Home measurement devices should be checked regularly.





# Korotkoff Sounds

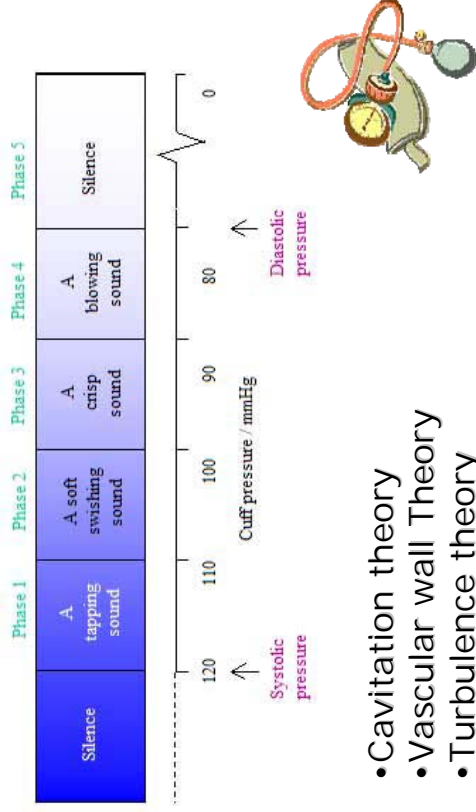

- Cavitation theory
- Vascular wall Theory
- Turbulence theory

# History

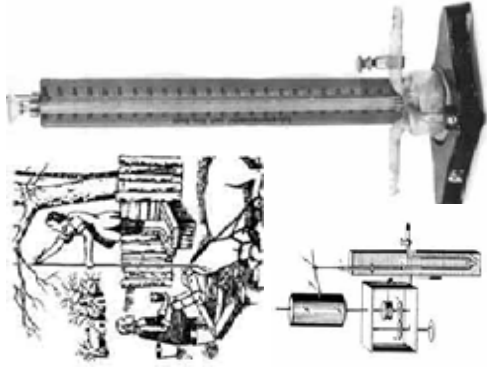

- 1733; Reverend Stephen Hales
- 1847; Carl Ludwig's kymograph
- 1896; Scipione Riva-Rocci
- 1905; Nikolai Korotkoff

# Pros & cons of current devices

- **Mercury sphygmomanometer**
  - Pros: Gold standard, easy to understand and use
  - Cons: Mercury, maintenance, operation bias
- **Aneroid sphygmomanometer**
  - Pros: Mercury free, well-understood by users, easy calibration
  - Cons: Prone to observer bias, wear & tear
- **Semi-automated devices**
- **Automated devices**
  - Pros: Mercury free, no observer bias, easy to use
  - Cons: Home originated, not for all patients, difficult to calibrate, hygiene issue

# Problems with mercury sphygmomanometer

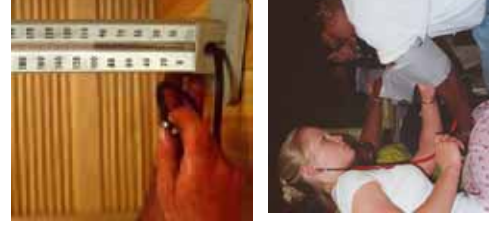

- Mercury vapor is poisonous.
- Black discoloration with time.
- Mercury column kept rising after inflation stopped.
- Cuff does not rise with inflation.
- Observer bias.

## JNC 7

- Patients should be seated in a chair with their backs supported with their arms bared and supported at heart level.
- Measurement should begin after at least 5 minutes of rest.
- The appropriate cuff size should be used.
- Measurement should be taken with a mercury sphygmomanometer, recently calibrated aneroid manometer or a validated electronic device.
- Both systolic and diastolic measurements should be recorded.
- Two or more readings separated by 2 minutes should be averaged. If first two readings differ by more than 5 mmHg, additional readings should be obtained and averaged.

## BP measurement in practice

- 61% knew currently accepted practice for identifying systolic BP
- 71% knew currently accepted practice for identifying diastolic BP
- 62% properly determined deflation rate
- 54% correctly interpreted a description of BP sounds containing an auscultatory gap
- 58% could identify faulty equipment
- 57% could assess proper cuff size
- 29% correctly determined inflation pressure
- 14% correctly determined arm position for seated measurement.

"Nurses' Knowledge of Error in Blood Pressure Measurement Technique"  
International Journal of Nursing Practice, R. Armstrong, June 2002.

## BP measurement in practice

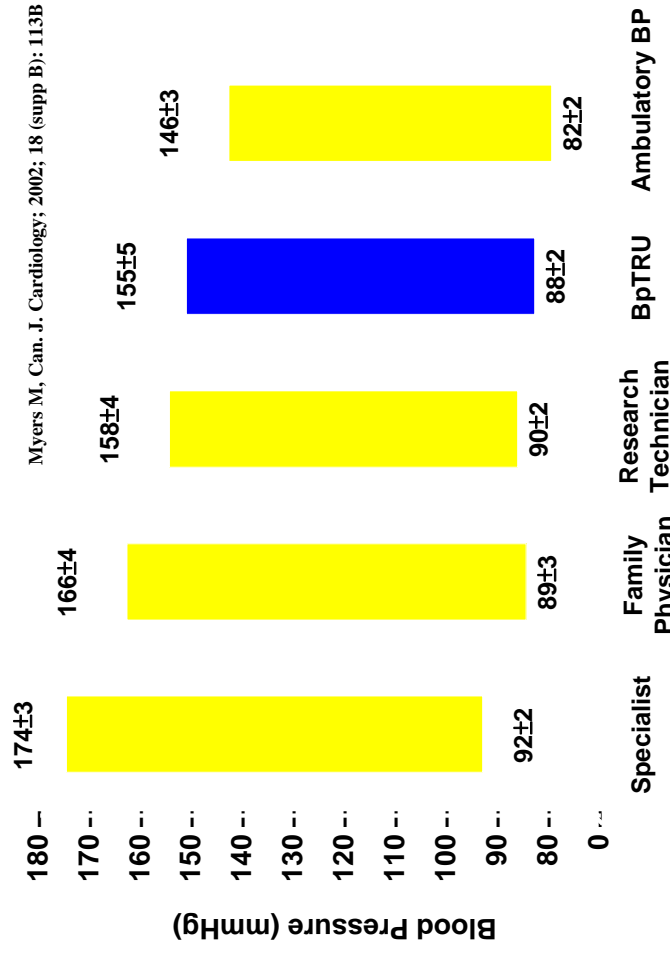
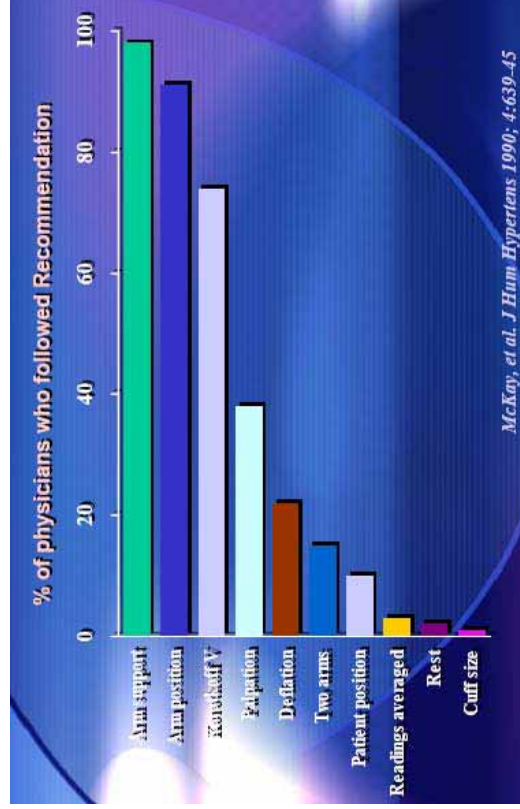

## Justification for ousting mercury

- Mercury toxicity
- Regulations regarding use in work place
- Attempts to eliminate human errors



## Major concerns

- Validation
  - Children
  - Senile citizen
  - Pregnancy
  - VHD
  - Arrhythmias; Af
- Calibration
  - Difficulties



## Expectations

- Accurate & intelligent
- Economic
- Small & portable
- Easy to use
- One fits all
- Durable
- Easy to calibrate

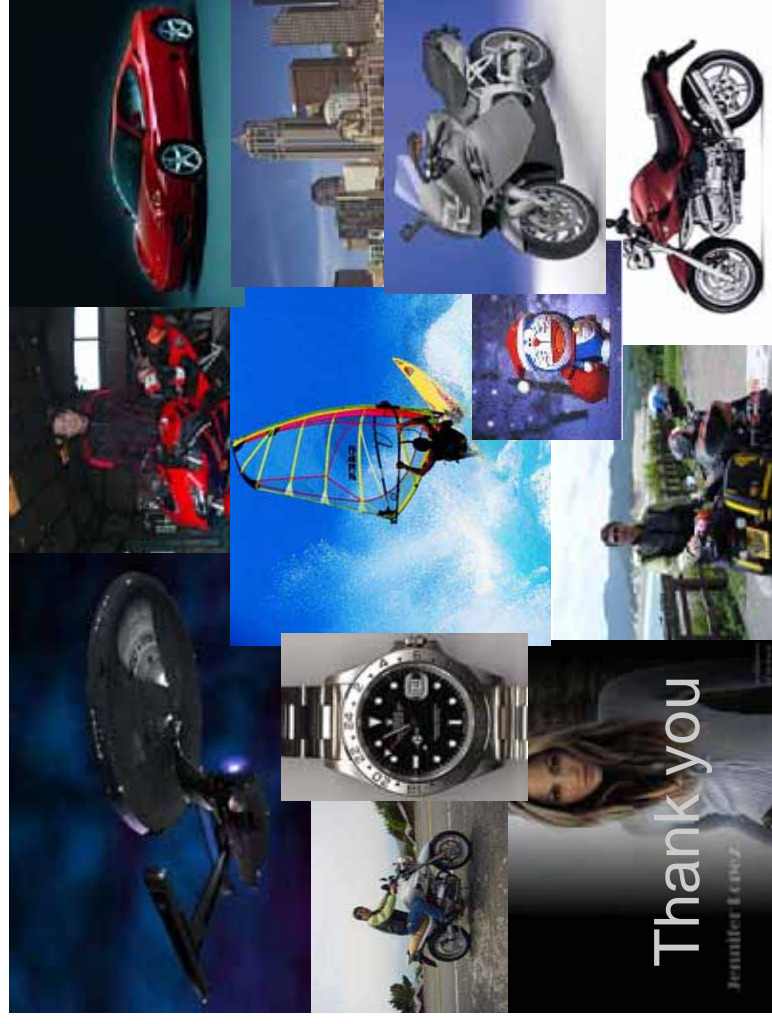

## The Accuracy and Traceability of Non Invasive Automated Sphygmomanometers

*Chen-Chuan Hung  
Measurement Standard & Legal Metrology Division  
Center for Measurement Standards / ITRI  
Bldg. 08, 321 Kuang Fu Rd, Sec. 2  
Hsinchu, Taiwan 300, R.O.C.  
Tel: 886-3-5743788  
Fax: 886-3-5724952  
E-mail: c-chung @itri.org.tw*

### Principles (continue)

- The pressure value corresponding to the mercury column is the systolic pressure, when the first sound appears
- The sound becomes louder and then deep and low. The pressure value when the sound finally disappears is the diastolic pressure
- The non invasive automated sphygmomanometer applied on the upper arm was first market launched in 1975.

### Principles

- The conventional method is to monitor the sounds generated by the flow of blood during the inflation and deflation of a blood pressure cuff using a stethoscope
- When the pressure of the cuff is greater than intravascular pressure, the blood in the upper arm fails to pass through the cuff and no sound can be heard from the stethoscope
- when the pressure of the cuff gradually releases, blood can pass through the cuff

### Principles (continue)

- The automated oscillometric sphygmomanometer was first launched in about 1985.
- When the cuff becomes inflated and deflated, pressure oscillations continuously occur due to the fluctuations of arterial blood pressure.
- The oscillations increase to a maximum amplitude and then decrease until the cuff fully deflates.
- These oscillation signals and cuff pressure are stored; the systolic pressure and the diastolic pressure are derived on the basis of them through a proprietary algorithm developed by the manufacturer of the device.

## The Weights and Measures Act

- Legal measuring instrument: a measuring instrument that is designated by the competent authority for use in trade, certification, official inspection and testing or environmental protection activities, or is related to public safety and/or medical and health care affairs (mechanical sphygmomanometer and automated sphygmomanometer)

## The Weights and Measures Act(continue)

- Matters related to metrological affairs shall be handled by a dedicated authority (Ministry of Economic Affairs ) as designated by the competent authority (medical devices shall first be inspected and registered by the Department of Health and then be subjected to type approval and verification)
- In order to ensure fair trade and to maintain proper public safety and health and environmental protection, the competent authority may designate measuring instruments that are provided for use ...(the use of mercury shall be banned for measurement in the future)

## Overall System Accuracy of NIBP

- Maximum permissible errors of the overall system as measured by clinical tests
- 1. Requirement of OIML R16-2 (Taiwan will follow this standard)
  - maximum mean error of measurement:  $\pm 0.7$  kPa ( $\pm 5$  mmHg)
  - maximum experimental standard deviation: 1.1 kPa ( 8 mmHg)
- 2. Requirements of EN 1060 and AAMI SP10
  - maximum mean error of measurement:  $\pm 0.7$  kPa ( $\pm 5$  mmHg)
  - maximum experimental standard deviation: 1.1 kPa ( 8 mmHg)

## Maximum permissible errors of the cuff pressure indication

- NIBP accuracy determined by comparison with static pressure standard
- 1. Requirement of OIML R16-2 (15°C-25°C)
  - $\leq \pm 0.4$  kPa ( $\pm 3$  mmHg) in case of verifying the first time
  - $\leq \pm 0.5$  kPa ( $\pm 4$  mmHg) for sphygmomanometers in use
- 2. Requirement of EN 1060 (15°C-25°C)
  - $\leq \pm 0.4$  kPa ( $\pm 3$  mmHg)
- 3. Requirement of AAMI SP10
  - $\leq \pm 3$  mmHg (18°C-33°C)
  - $\leq \pm 3$  mmHg or 2 % whichever is greater (10°C-17°C and 34°C-40°C )

## Verification and Inspection of NIBP in Taiwan (The Weights and Measures Act)

- **Verification:** examination and testing of a legal measuring instrument to ensure that it complies with related metrological requirements (full verification for new products and re-verification)
- **Inspection:** examination and testing of a verified legal measuring instrument in use to ensure that it continues to comply with metrological requirements (irregularly, approximately once a year)

## Verification and Inspection of NIBP in Taiwan(continue)

- **Technical Specification for Verification and Inspection of Non Invasive Automated Sphygmomanometers** (announced on Dec.2005, will be carried out on Dec.2009)
  - The maximum permissible error of verification is  $\pm 3$  mmHg ( $\pm 0.4$ kPa)
  - The maximum permissible error of inspection is  $\pm 4$  mmHg ( $\pm 0.5$ kPa)
  - The period of validity of verification is 2 years

## Type Approval of NIBP in Taiwan

- **Technical Specification for Type Approval of Non Invasive Automated Sphygmomanometers (Draft)**
  - Refer to OIML R16-2 Non-Invasive Automated Sphygmomanometers ( 2002 )
  - **The Weights and Measures Act:** The dedicated weights and measures authority may approve and designate laboratories to conduct tests of the measuring instruments requiring type approval (execute by verified laboratory through BSMI committee)

## The measurement standard of NIBP in ITRI

- **Establish primary mercury manometer and Piston gauge**
- **Collect Validated Database from Clinical trial**
- **Establish Standard blood pressure simulation system to replay real human bio-signal recorded earlier in the clinic**

## Laser Interferometer Mercury Manometer

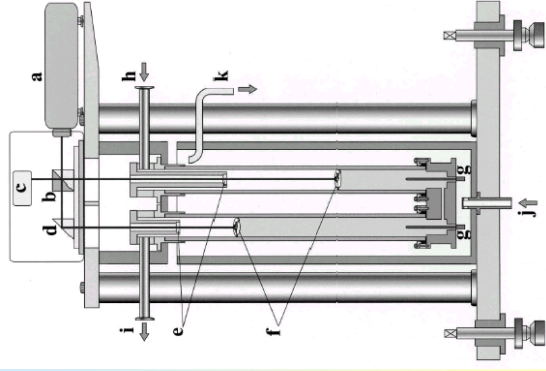

- Pressure Range : 1 ~ 120 kPa
- Expanded Uncertainty : 0.5 ~ 1 Pa

## Gas Piston Gauge



- Pressure Range : 17~172 kPa
- Expanded Uncertainty :  $3.0 \times 10^{-5}$

## Quartz Bourdon Tube



- Pressure Range : 0~414 kPa
- Expanded Uncertainty : 0.02 kPa

## Validated Database from Clinical trial

- Select 85 subjects at least three measurements shall be carried out with recording unit both in upper arm and wrist according to OIML R 16-2 recommended protocols for the clinical investigations are given in:
- The British Hypertension Society protocol for the evaluation of blood measuring devices.
- DIN 58130: 1995,(EN1060)-was substituted by e
- AAMI/ANSI SP10, American National Standard for electronic or automated sphygmomanometers

## Measuring procedure

- 85 subjects-255 paired determinations

Recording Unit at upper arm

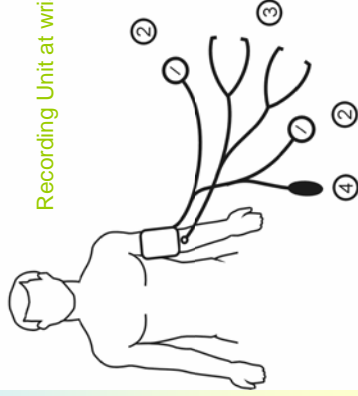

Recording Unit at wrist

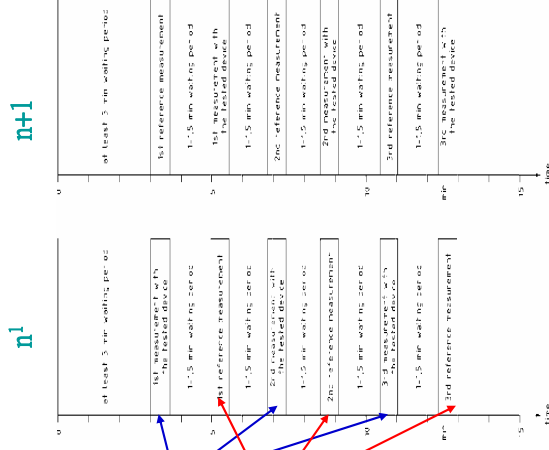

- Recording of cuff pressure, korotkoff sound and ECG is optional, to be adjusted by the user. Data will be stored on hard disk directly.
- Blood pressure measurement taken by two independent observers by using a dual-headed stethoscope with a thin round microphone.
- The sex, ages, height, weight, artifact, reference systolic and diastolic pressure for inflate and deflate limits will be on the screen during the measurement.

## Recording Unit

- A Recording Unit will be used for the recording of different blood pressure signals which will be archived for cuff pressure and korotkoff sound use as input to construct a simulator and to replay the signals. Blood pressure measurements can be done automatically at the wrist and upper arm.

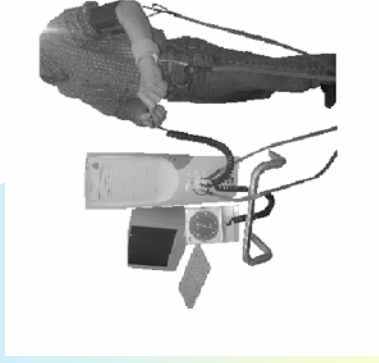

## Standard blood pressure simulation system

- To generate the real human oscillomatic pulses recorded earlier in the clinic.
- Control the membrane-lever to be able to replicate the recorded human signals as real as possible





# Standard blood pressure simulation system(continue)

- Calibration software is necessary for calibration of pressure transducer, level position and different volumes of pneumatic system of the tested device.
- Data processing to prepare the data for the simulation including cuff pressure, pulse rate and deflation rate.
- It is necessary to split the recorded cuff pressure oscillation curve into segments consisting of a single pressure pulse. This is done automatically, but it can be modified by hand.
- A data record consists of at least 4 files, these are storing the signals of cuff pressure, Korotkoff sound, electrocardiogram and patient data.

## 標準人體血壓模擬與量測技術研發

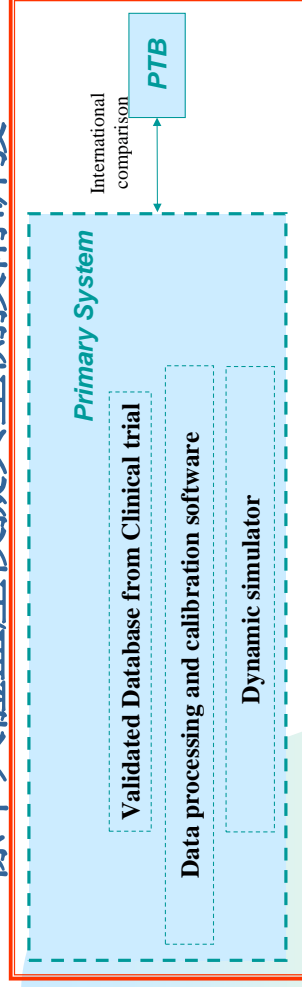

- Develop standard blood pressure simulation system by the cooperation with PTB
- > 255 subjects Validated Database from Clinical trial
- Substitution of clinical trial by database of validated oscillograms

# The Traceability of NIBP

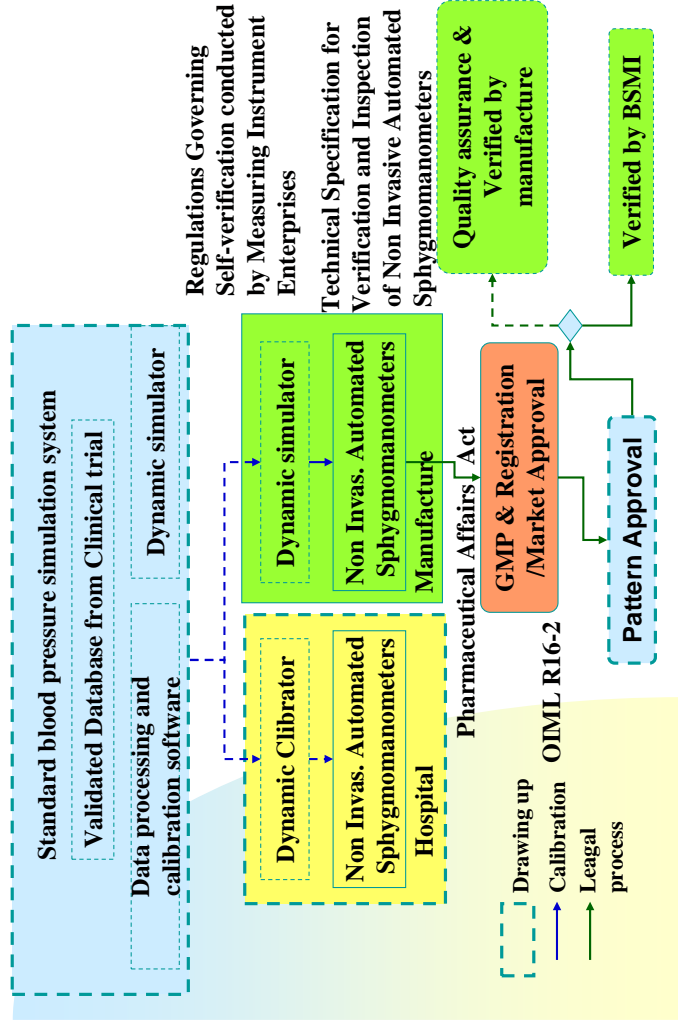

# Calibration services for Hospitals & Manufacturers

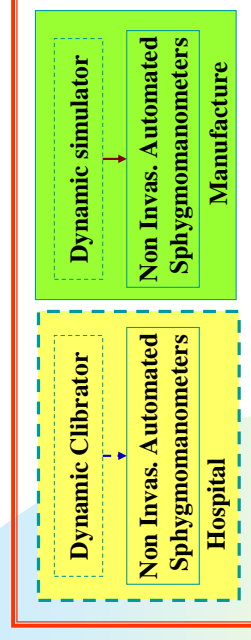

- Calibrate simulators
- Calibrate sphygmomanometers
- Calibrate pressure sensors
- Measure the precision of diagnosis and the efficacy of therapy

## Pattern approval

- To Be A Conformity Assessment Body (CAB) of the medical devices with a measuring function for BSMI/MOEA & DOH
- Execute pattern examination of non-invasive automated sphygmomanometers

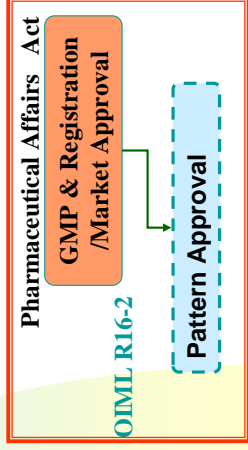

## Solutions for manufacturers' needs

- Assist manufacturers in establishment of quality systems (ISO..., EN... and FDA...)
- Be a Conformity Assessment Body (CAB) of Measurement Assurance Program (MAP) to Mainland China
- Establish automatic test systems for electr. non-invasive sphygmomanometer on “同” Mark self-declaration

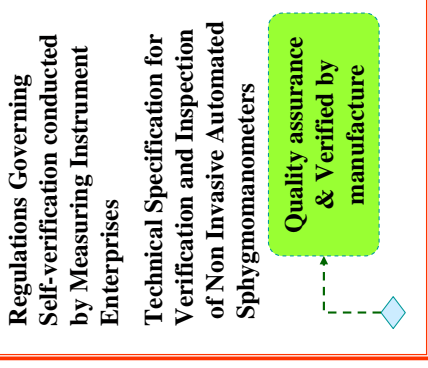

## Solution for verification by BSMI

- Setup automatic verification systems for electr. non-invasive sphygmomanometer on “同” Mark



Thank You

Country Report  
of  
the Kingdom of Cambodia

Seminar  
on  
Automated Sphygmomanometers  
from July 17-21, 2006  
In Taipei, Chinese Taipei

by  
Mr. KIM Chandara  
Deputy Director,  
Department of Metrology  
Ministry of Industry, Mines and Energy

**1- Brief History**

- 1995 Establishment of Weights and Measures Unit under the Technical Department of Ministry of Industry, Mines and Energy (MIME).
- 1999 Upgraded to be the Department of Metrology (DOM), under MIME.
- 2000 Became the Corresponding Member of OIML.
- 2002 Became the Full Member of APLMF.

**2- Structure of Metrology**

Recently, the Metrology of Cambodia is split between the Department of Metrology (DOM) and Industrial Laboratory Center of Cambodia (ILCC).

DOM has the responsibility for all Legal Metrology Activities and keeps the Secondary and Working Standards.

ILCC keeps the Primary Standard and also implements the Industrial and Scientific Metrology requested by DOM. Our structure is in Annex No 01.

**3- Self-Introduction.**

Who am I?

My name is KIM Chandara. You can call me KIM. I have been working in Metrology since 1996. Presently, my position is Deputy Director of Department of Metrology (DOM), in charge of International Cooperation, Metrological Technology Development and Testing Laboratories. I assist also my Director to organize the training of metrological staff.

Now, I do not have any experience on Type Approval or Verification or Re-verification of medical devices including Thermometer or Automated Sphygmomanometers.

#### **4- Situation of Automated Sphygmomanometers in Cambodia**

In Cambodia, mostly of sphygmomanometer used in hospitals, clinics, family use are imported from China, Japan, Germany, USA and others.

There are more than 20,000 medical staffs in Cambodia used about 5% of Mercury Sphygmomanometer, 85% of aneroid sphygmomanometer and 10% of Automated Sphygmomanometer which is day to day increasing.

#### **5- Metrological control on Automated Sphygmomanometer**

Measuring Unit used for the Automated Sphygmomanometer is Millimeter Hg (mmHg).

Presently, medical devices including Thermometer or Sphygmomanometer are not subject to any regulatory control at the moment. Pattern Approval and Verification such instruments are not legally enforced.

DOM is interested in this matter because in the drafted law of metrology of Cambodia there is one article has prescribed on public health safety. Now Cambodia does not have measurement standard and regulation of verification or inspection. These devices are very important for Health and lives; therefore it must be inspected and verified.

#### **5- Metrological control on Automated Sphygmomanometer (con't)**

We foresee that the medical devices regulation coming force in the future. So we need to upgrade of Technical competence and capability.

The adoption of OIML recommendation in the Technical Regulation is envisaged. We hope to learn the methods equipment requirements for a good verification. Therefore the participation to this training course will be very important for me to get and share experience from lecturers and colleagues participants of these matters.

#### **6- Acknowledgement**

Finally on behalf of myself, I would like to express my sincere thanks to Dr. MATSUMOTO who has supported me to this training courses and particularly all lecturers and organizers who have always contacts and facilitated me before and during the training courses.

Thank you for your kind attention.

Annex 1  
**Organization Chart**

**Ministry of Industry, Mines and Energy**

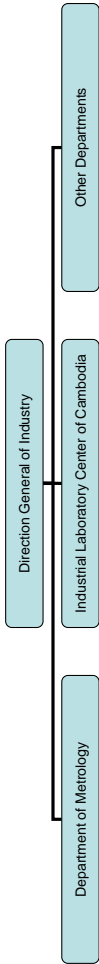

Under DoM:

**1- There are five offices**

- a- Admin. and Legislation.
- b- Control-Verification.
- c- Technological Development of Metrology.
- d- Provincial Management Metrology.
- e- Tax-Accounting.

**2-Room Verification of DoM, consists of**

- a- Mass Section.
- b- Volume Section.
- c- Temperature Section.
- d- Pressure-Force Section.
- e- Dimensional Section.
- f- Electricity Section.

**3- Five Regional Verification Centers (Regional).**

**4- Twenty-four Provincial Metrology Offices (Local).**

Under ILCC:

**- There are two Laboratories**

- a- Food, Microbiology, Chemical Lab.
- b- Scientific, Industrial Metrology Lab.

COUNTRY REPORT

APEC/APLMF Seminar and Training Course in Legal Metrology  
(CTI-11/2006T)  
Seminar on Automated Sphygmomanometers  
on Juli 17 – 21, 2006 at the Howard International House  
in Taipei, Chinese Taipei

Presented by  
Nino Wawan SETIAWAN

DIRECTORATE OF METROLOGY  
DIRECTORATE GENERAL OF DOMESTIC TRADE  
THE MINISTRY OF TRADE OF THE REPUBLIC OF INDONESIA



General Overview of Indonesia

- Official Name: Republic of Indonesia
- Population: ± 238.452.952
- Capital City: Jakarta
- Languages: Bahasa Indonesia (official), English, Dutch, local dialects, the most widely spoken of which is Javanese
- National Anthem: Indonesia Raya
- Official Currency: Rupiah
- Location: Southeastern Asia, between Australia & Asia Continents, archipelago between the Indian Ocean and the Pacific Ocean,
- Main Islands: Sumatra, Java, Kalimantan, Sulawesi & Irian
- Provinces: Indonesia has 33 provinces
- Climate: tropical; hot, humid; more moderate in highlands, seasons; dry and wet
- Surface area : 1.900.000 km<sup>2</sup>
- Latitude/Longitude 6° 18S, 106° 83E



● Directorate of Metrology is located in Bandung

Overview of Directorate of Metrology  
and local Metrology offices

Directorate of Metrology is under the Ministry of Trade,  
Directorate General of Domestic Trade

Directorate of Metrology to consist of:

1. Sub Directorate of Metrological Facility and Human Resource
2. Sub Directorate of Metrological Cooperation
3. Sub Directorate of Measurement Standard and Metrological Laboratory
4. Sub Directorate of Metrological Technique
5. Sub Directorate of Supervision and Metrological Information

The main tasks of the Directorate of Metrology are:

- to conserve reference standards,
- to draw up technical regulations for measuring instruments,
- to recruit, educate and train metrology officials (metrology engineers and legal metrology technicians),
- to carry out type evaluation and to issue type approvals for measuring instruments to be imported or produced,
- supervise legal measuring instrument; and pre-packaged goods and giving metrology information;
- to implement relations with the OIML

Directorate of Metrology is the national issuing authority for Type Approval Certificate for imported measuring instruments and domestic product of measuring instruments

## The Organizational Structure of Directorate of Metrology

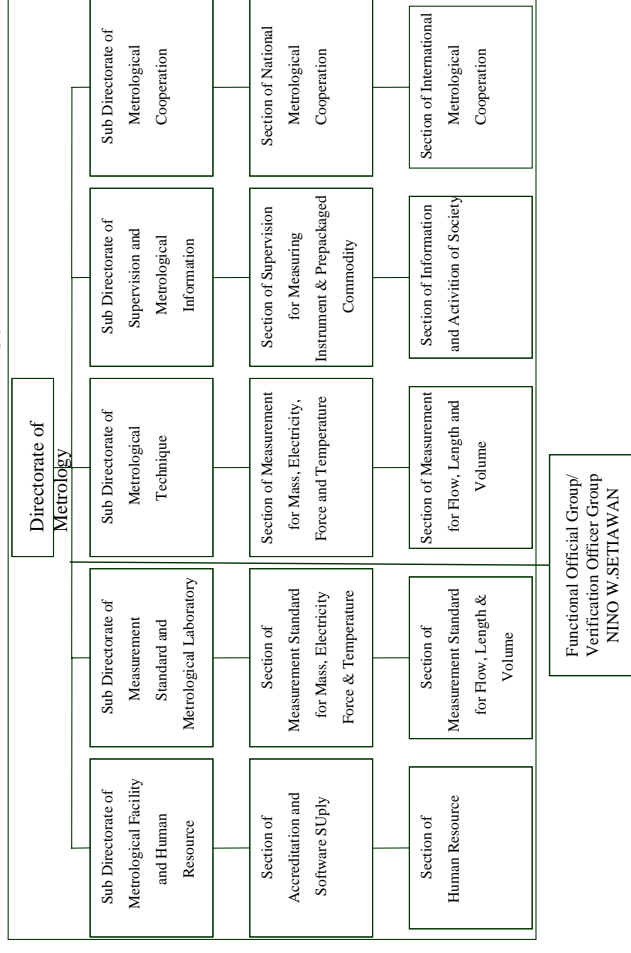

### Laboratory of the Directorate of Metrology

- Laboratory of Mass
- Laboratory of Force
- Laboratory of Pressure
- Laboratory of Length
- Laboratory of Volume
- Laboratory of Temperature
- Laboratory of Electric
- Laboratory of Health & Environment

### Local Metrology Offices:

There are fifty-five local metrology offices throughout Indonesia.

Their main tasks are:

- to manage physical reference standards,
- to verify measuring instruments and control reliability of mass, volume or total content of pre-packed goods,
- to investigate contraventions of the Legal Metrology Law.

## MEASUREMENT LAW & REGULATIONS

- ➔ **Measurement Law : No. 2, 1981 Regarding Legal Metrology**
- ➔ **Regulations :**
  1. **No. 2, 1985 concerning Measuring Instrument subject to verification**
  2. **No. 10, 1987 concerning Legal Units of Measurement**
  3. **No. 7, 1989 concerning the National Standardization Council**
  4. **No. 2, 1989 concerning the National Standards for Measurement Units,**

*and so on.*

## Instrument subject to legal control

Measuring instruments used in :

- the public domain,
- custody transfer,
- determination of yield and wage,
- trade or business transaction,
- determination of factory final product,
- enforcement of regulation,

are subject to legal control. This covers measuring instruments for: mass, length, volume, moisture, force, pressure, electrical power, taximeters and its standards.

## Number of Verification officer

**Directorate of Metrology:**  
51 persons (male: 46 persons, female: 7 person)

**Local Metrology Office:**  
900 persons (spread out in 55 offices)

## Type Approval and Verification of Automated Sphygmomanometers

- **Type Approval of Automated Sphygmomanometers**  
Directorate of Metrology didn't have issuing authority for Type Approval Certificate for imported measuring instruments and domestic product of measuring instruments
- **Calibration of Automated Sphygmomanometers**  
Calibration of Automated Sphygmomanometers are carried out by OIML Recommendation (R16-2)



## Calibration methods

an calibration of instrumental error shall be carried out by :

OIML METHODS TO COMPARE  
STANDARD AND UNDER TEST

## Reference:

- OIML R 16-2 : Non-invasive automated sphygmomanometers
- Ministerial Decree No. 61/MPP/kep/2/1998 concerning Type Approval of Measuring Instruments

**Terimakasih atas Perhatiannya**

**thank you very much  
for your attention**

*Chinese Taipei, July 21, 2006*

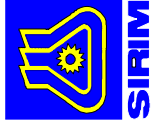

## Current Situation In Malaysia Regarding The Control Of Instruments For Medical Use

Presented by:  
Ms. Hairani Nordin  
Metrologist, Mechanical Metrology Section  
NML-SIRIM, MALAYSIA

July, 2006

The main provisions of the Act are briefly described as below:

1. The Act prescribes the use of the International System of Units (S.I.) as the only legal units to be used in Malaysia.
2. It provides for the appointment of a Custodian of Weights and Measures to realise, establish and maintain national measurement standards to provide traceability of msmt to verification standards used for legal enforcement.  
  
The NML-SIRIM carries out the duties and responsibilities of the Custodian.
3. A system of metrological control of measuring instruments for trade use is regulated under this Act. It is effected through the requirement for pattern approval of new instruments by the Custodian and the verification and re-verification of the measuring instruments by the Inspectors of Weights and Measures.

### 1. General

#### Weights and Measures Act 1972

Main legislation regulating weights, measures and measuring instruments in Malaysia. The Act is enforced by the Ministry of Domestic Trade and Consumer Affairs.

### 2. Control of Measuring Instruments for Medical Use

Measuring instruments for medical use such as clinical thermometers, sphygmomanometers, haemocytometer dilution pipettes, etc are not subject to any regulatory control at the moment. Pattern approval and verification of such instruments are as such not legally enforced.

The Ministry of Health however is currently drafting an Act on Medical Devices which will emphasize on the need for all medical devices procured to meet with certain standards.

Common Type of Sphygmomanometer used by medical practitioners in Malaysia :

- (i) Mercury Manometer
- (ii) Elastic Sensing Element (e.g Dial Type)

### 3. Current Direction

- ↘ Joined the International Organization of Legal Metrology (OIML) as a corresponding member in 1989 and has since gradually adopted a number of OIML international recommendations and guidelines for its pattern evaluation and verification procedures.
- ↘ A member of the Asia Pacific Legal Metrology Forum and has participated in a number of training courses, workshops, meetings since its inception in November 1994.
- ↘ Will continue to maintain liaison and cooperation with regional and international organizations to keep abreast with the developments in legal metrology in its effort to achieve harmonization, mutual recognition and upgrading of technical competence and capability.

### 4. Future Direction

- ↘ It is foreseen that with the Medical Devices Act coming into force in the near future some regulatory control on sphygmomanometers including other medical instruments will be enforced. The adoption of OIML recommendations in the technical regulations is envisaged.

**Thank You**  
**For Your Attention**





**NATIONAL METROLOGY LABORATORY,  
SIRIM BERHAD, MALAYSIA**

**Current Situation In Malaysia Regarding The Control Of Instruments For  
Medical Use.**

**1. General**

The Weights and Measures Act 1972 is the main legislation regulating weights, measures and measuring instruments in Malaysia. The Act is enforced by the Ministry of Domestic Trade and Consumer Affairs. The main provisions of the Act are briefly described as below:

- (i) The Act prescribes the use of the International System of Units (S.I.) as the only legal units to be used in Malaysia.
- (ii) It provides for the appointment of a Custodian of Weights and Measures to realise, establish and maintain national measurement standards to provide traceability of measurements to verification standards used for legal enforcement. The National Metrology Laboratory in SIRIM Berhad carries out the duties and responsibilities of the Custodian.
- (iii) A system of metrological control of measuring instruments for trade use is regulated under this Act. The control is effected through the requirement for pattern approval of new instruments by the Custodian and the verification and reverification of the measuring instruments by the Inspectors of Weights and Measures.

While the scope of the Weights and Measures Act covers all fields of measurements its existing provisions are very much focussed on the regulation of fair trade practices and control of measuring instruments used in the direct retail trade sector. As a result the effective control of measuring instruments used in other fields of trade measurements is delegated to other regulatory authorities.

**2. Control of Measuring Instruments for Medical Use**

Measuring instruments for medical use such as clinical thermometers, sphygmomanometers, haemocytometer dilution pipettes, etc are not subject to any regulatory control at the moment. Pattern approval and verification of such instruments are as such not legally enforced.

The Ministry of Health however is currently drafting an Act on Medical Devices which will emphasize on the need for all medical devices procured to meet with certain standards.

As regards the sphygmomanometers the most common type used by medical practitioners in Malaysia is the mercury manometer type followed by

manometers with an elastic sensing element. Automated sphygmomanometers are used to a lesser extent but are gradually increasing in home use.

### **3. Future Direction**

Malaysia joined the International Organization of Legal Metrology (OIML) as a corresponding member in 1989 and has since gradually adopted a number of OIML international recommendations and guidelines for its pattern evaluation and verification procedures.

Malaysia is a member of the Asia Pacific Legal Metrology Forum and has participated in a number of training courses, workshops, meetings since its inception in November 1994.

Malaysia will continue to maintain liaison and cooperation with regional and international organizations to keep abreast with the developments in legal metrology in its effort to achieve harmonization, mutual recognition and upgrading of technical competence and capability.

It is foreseen that with the Medical Devices Act coming into force in the near future some regulatory control on sphygmomanometers including other medical instruments will be enforced. The adoption of OIML recommendations in the technical regulations is envisaged.

# SEMINAR ON AUTOMATED SPHYGMOMANOMETERS

July 18 – 22, 2006

Howard International House, Taipei, Chinese Taipei



**MONGOLIAN AGENCY FOR  
STANDARDIZATION AND METROLOGY**

**Dashrenchin Bayasgalan**

Verification Officer

Verification Laboratory of Heat and Pressure Measuring Instruments

E-mail: [masm@mongol.net](mailto:masm@mongol.net) , Tel: +976-51-263971, Fax +976-11-458032

**MONGOLIAN AGENCY FOR STANDARDIZATION AND  
METROLOGY**



## MAP OF MONGOLIA

Location: Northern Asia, between China and Russia



Capital: Ulaanbaatar

Total population: 3.0 million (July 2006 est)

Area: 1.565 million sq km.

**MONGOLIAN AGENCY FOR STANDARDIZATION AND  
METROLOGY**

The main functions are:

- Standardization
- Certification
- Establishment of national measurement standards
- Legal metrology
- Accreditation
- State supervision of standardization, quality and metrology
- Training and consulting
- International cooperation

## MASM

Mongolian Agency for Standardization and Metrology is a Government regulatory agency responsible for coordinating and managing the standardization, metrology, testing and quality sector throughout the country. MASM reports to the Deputy Prime Minister of Mongolia

### Mission

To contribute to the social and economic development of Mongolia in conjunction with the development strategic tendency by applying standardization, quality and metrology.

## MASM chart

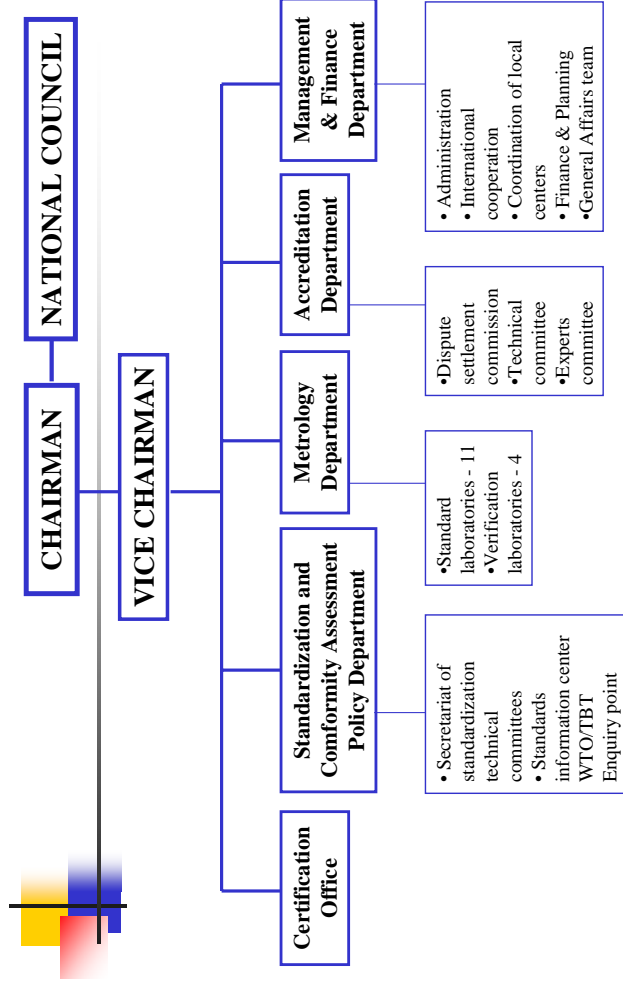

## Metrology Department

Main activities:

- Development of national standards system
- Maintenance and improvement of accuracy of measurement standards
- Traceability of measurement standards
- Development and registration of Certified Reference Materials
- Calibration of measurement standards and measuring instruments with high accuracy
- Proficiency testing scheme
- Pattern approval of measuring instruments
- Licensing for manufacture, repair, installation and sale of measuring instruments

## Metrology Department

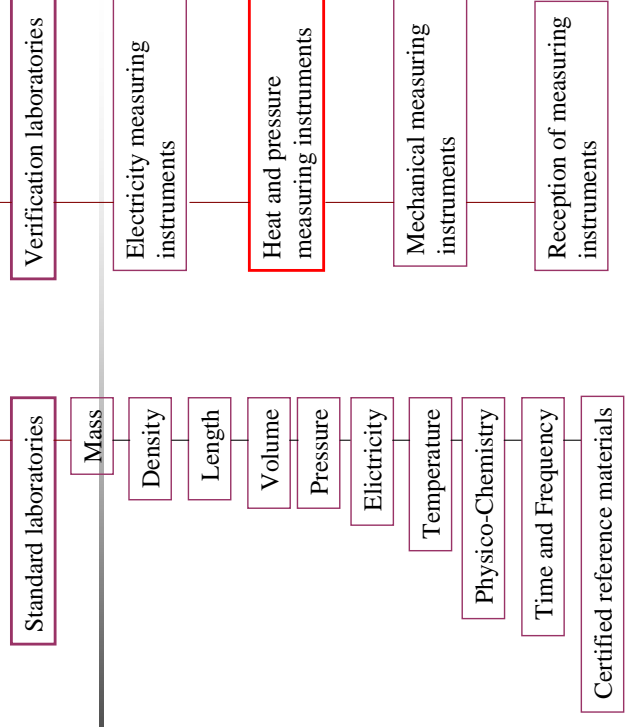

## LEGAL METROLOGY

### Main activities:

- Verification of mandatory instruments as required by law
- Pattern approval of measuring instruments
- Licenses for manufacture, repair, service and sale of measuring instruments
- Training

## Verification laboratory of heat and pressure measuring instruments



The heat and pressure measurement laboratory is one of first laboratory of MASM and build up in 1963.

The heat and pressure measurement laboratory aims to engage functions of government Supervision and control over the heat and pressure measurements.

Today in the heat and pressure measurement field 46 thousand measuring equipments of 16 types are used in Mongolia.

## Heat and Pressure measuring instruments

The main functions:

- Pattern approval of heat and pressure measuring instruments
  - Verification of mandatory heat and pressure measuring instruments as required by law
- In the verification laboratory, using below working standard:
- Temperature: 0.05 °C in range of (-45 to 300) °C
  - Pressure: 0.05 % in range of (-1 to 600) bar
  - Heat: 0.2 % in range of (0 to 80) m<sup>3</sup>/h

Also the our laboratory verified heatmeter and steammeter of all type use in the Mongolia

## Sphygmanometers



Today mercury, aneroid and automated sphygmomanometers are widely used in medical fields of Mongolia.

About 2500 sphygmomanometers used in the medical institutes.

Almost of them are made Russia, China, Germany, Japan.





- The laboratory has equipped by precision dead weight tester type MP-04 with accuracy 0,05 made in Russia.
- Also has equipped by precision dead weight intelligent pressure calibrator type HX600B with accuracy 0,05 made in China.
- According to recommendations OIML R 16 -1 by the direct method verified sphygmomanometers mechanical type.



## *Automated Sphygmomanometers*



Present time our laboratory couldn't verify any automated sphygmomanometer.

Reason of them

- haven't measurement standard
- haven't standard method of the verification



## *Current position in the Mongolia*

According to the Mongolian law on "Traceability of Measurement Uniformity", mandatory measuring instruments are including sphygmomanometers verified by the verification body.

Even so, in the our laboratory have not test equipment or instruments, the automated sphygmomanometers can not be verified recently.

Future, the body is planning to prepare national standard on the test or calibration of the rical automated sphygmomanometers, and to purchase necessary test equipment or instruments.

## *Summary*

Effectiveness of participating in this seminar are taking understanding about general knowledge of automated sphygmomanometers, requirements on them and other international test methods or standard of verification, and studying standard test or calibration equipment and measuring instruments.



*Thank you for  
your attention*



## PAPUA NEW GUINEA NATIONAL INSTITUTE OF STANDARDS & INDUSTRIAL TECHNOLOGY

## The NISIT Structure

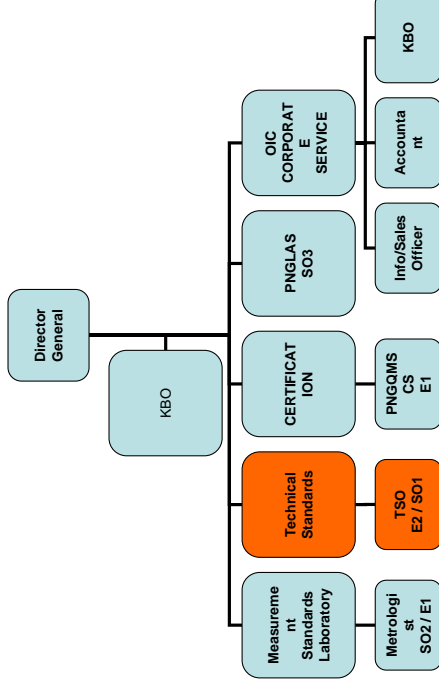

## NISIT in Brief

- An Act Passed By Parliament in 1993 known as the NISIT Act 1993
- To excel as Authority in PNG on standardization, be officially recognized as technically competent to assist manufacturing and service industries including infrastructure services in assuring sustainability of quality products, services or process to satisfy customers needs thru the use of standards

## Measurement Standards Laboratory

- (MSL) – department in NISIT
  - Establishment and Maintenance of the National Measurement System
  - Dissemination of the National Measurement Standards, and
  - Providing Technical Support & Training

**Health Department**  
**Immediate Regulators of All Medical Instruments in Papua New Guinea**

- Protection Body
  - Regulate under:**
  - ✓ Health Act
  - Under the NISIT Act 1993:**
- NISIT is mandated to carry out and implement legal metrology in the country

**Current Practice**

- The Health Department Automated Sphygmomanometers are widely used in almost all major public hospitals all over the country.
- Non-Invasive Blood Pressure Monitor (NI BP) ..... 18%
- Aneroid / Mercury ..... 82%

**Automated Sphygmomanometers**

- Unit of measure > mmHg
- Management of Sphygmomanometers including other medical devices are guided by AS/NZS 3551:2004: Technical management programs for medical devices
- Type approvals are not required at present since PNG does not manufacture such equipments and other devices in general
- Verification of sphygmomanometers is highly necessary and is usually performed by Health Department (NISIT, ICCG)
- At present OIML Recommendation (R 16-2) is not implemented as it is not clearly understood. To date there are no other regulations on sphygmomanometers other than the OIML Recommendations

**CONSTRAINTS:**

- Not enough funding for verification work for medical equipment by the Government
- No properly trained experts to carry out verification on medical instruments
- Lack of awareness in the area of Legal Metrology

## Way Forward

- NISIT hopes to gain from this training:
  - Update on verification procedures of Automated Sphygmomanometers
  - Through the NISIT Act 1993, work with Department of Health to build up a working system to check on Automated Sphygmomanometers as well as other Medical Equipment
  - Make awareness to the Health Sector of PNG on Legal Metrology and its importance in the Health Industry

**END!**

*Thank you very much for  
your kind attention!*

# SEMINAR ON AUTOMATED SPHYGMOMANOMETERS

CHINESE TAIPEI

July , 2006

NATIONAL METROLOGY SERVICE  
(SNM - INDECOPI) - PERU



LEONARDO DE LA CRUZ GARCIA

PRESSURE LABORATORY

## LOCATION

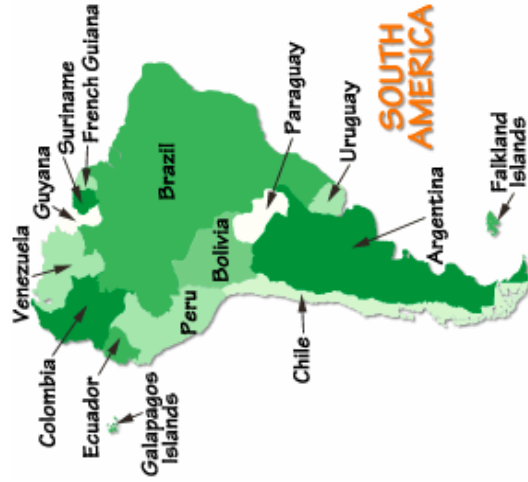

PERU IS A LATIN  
AMERICAN  
COUNTRY.

IT IS LOCATED IN  
THE CENTRAL  
AND  
OCCIDENTAL  
PART OF SUD  
AMERICA

## INFORMATION

- Country (long form) Republic of Peru
- Capital Lima
- Total Area 1 285 220,00 square kilometers
- Population 27 483 864 (July 2001 est.)
- Languages Spanish (official), Quechua (official), Aymara
- Religions Roman Catholic 90 %
- Government Type Constitutional Republic
- Currency 1 Nuevo Sol (S/.) = 3,28 Dollar (US\$)
- Industry mining of metals, petroleum, fishing, textiles, clothing, food processing, cement, auto assembly, steel, shipbuilding, metal fabrication
- Agriculture coffee, cotton, sugarcane, rice, wheat, potatoes, plantains, coca; poultry, beef, dairy products, wool; fish
- Peru has the biggest biodiversity of the world
- Natural Resources copper, silver, gold, petroleum, timber, fish, iron ore, coal, phosphate, potash, hydropower

# NATIONAL METROLOGY SERVICE - (SNM - INDECOPI) - PERU



**Address:**

**Calle De la Prosa 138**

**San Borja,**

**Lima 41- PERU**

**Tel. (+51-1) 224-7800- Anx 1331**

**Fax. (+51-1) 224-7800- Anx 1264**

**<http://www.indecopi.gob.pe>**

## INTRODUCTION

- Will you be required to train others?  
Yes, INDECOPI usually realizes courses about different types of instruments and to future it might realize courses on Sphygmomanometers.
- Do you have any experiences on type or verification or calibration of Automated Sphygmomanometers?  
In the Peru verification is not realized, only calibration (Aneroid type, mercury type, Electronic type)

## INTRODUCTION

- What is your position and responsibility in your economy?

I am head of Force and Pressure Laboratory in National Metrology Service – INDECOPI. My responsibility is to keep measurement standards and to transmit traceability to the industry. Also to establish standards methods in coordination with normalization area of INDECOPI. Then, these methods are used by laboratories or fiscalization offices.



INDECOPI

## Use of Automated Sphygmomanometers in my economy

How widely Automated Sphygmomanometers are used?

This type of instruments are used widely in the sector health ( hospital, university ).

Aneroid type 40 %

mercury type 40 %

Electronic type 20 %

## **Metrological control on Automated Sphygmomanometers in your economy**

What are the units of measure used for Automated Sphygmomanometers?

The units of measure used for this type of instruments are mm Hg.

Which organizations are responsible for the control and regulation over Automated Sphygmomanometers?

Department of Health is the responsible for the control and regulation.

## **Metrological control on Automated Sphygmomanometers in your economy**

Are type approvals required?

The type approvals and verifications are not required for Automated Sphygmomanometers in my economy.

Is OIML Recommendation (R16-2) understood and implemented?

No, only the R16-1

Thank you very much

Leonardo De la cruz

ldelacruz@indecopi.gob.pe



**APEC/APLMF Seminar and Training Course in Legal Metrology (CTI-11/2006T)**  
**Seminar on Automated Sphygmomanometers**

**July 17 – 21 July 2006**

Radley F. Manalo  
Science Research Specialist I  
National Metrology Laboratory  
Industrial Technology Development Institute  
Department of Science and Technology  
Philippines

## **Job descriptions**

- Perform measurements and calibrations including pressure gauges and calibrators, analog and mercurial sphygmomanometers, etc.
- Maintains and conduct functional tests on standards of the laboratory
- Maintain laboratory's good condition

## **Train Others**

- It is my duty to present a travel report as well as technical presentation in our organization to disseminate the knowledge gained to my colleagues after the training.
- A more detailed training will also be done to the staff of the laboratory through actual or hands-on practice
- Automated sphygmomanometers are not yet accepted in the laboratory since there is no procedure yet being followed, but with great demand on its calibration, future development is expected

## **Use of Automated sphygmomanometer**

- Mercurial sphygmomanometer 40%
  - Analog sphygmomanometer 25%
  - Automated sphygmomanometer 35%
- (These figures are only estimates)

## Typical Users

Automated sphygmomanometers are mostly used in household due to the ease of use. These sphygmomanometer are not typical in the hospitals but they readily available for the public

## Metrological Control

- Automated Sphygmomanometers use the unit mmHg.
- The NMB (BHDP-DOH, National Metrology Laboratory, ITDI, Bureau of Product Standards) are few organizations responsible for control and regulation of these devices
- Type approvals & verification are required but is not fully implemented. BHDP-DOH, and BPS (present)
- NML, ITDI (future)
- Yes, OIML recommendation (R16-2) is understood, but not yet implemented. but not yet implemented
- There is no regulation on automated sphygmomanometer in our country other than OIML.

## Measurement Standards

### National Metrology Laboratory, ITDI

- responsible for establishing and maintaining the national standards for the SI units of quantities (e.g. mass, length, temperature, voltage, pressure, etc.)
- dissemination of standard values to users at appropriate uncertainty levels is performed through the calibration and measurement services offered
- is equipped with high accuracy standards and comparators that are periodically calibrated and compared with those of other national metrology institutes abroad to ensure international traceability of its measurements done for the clients.

## Legal metrology development

### National Metrology Act

- approved on February 3, 2004
- establishment of the National Measurement Infrastructure System (NMIS)
- covers units of measurement, measuring instruments, their application and metrological controls, establishment of a laboratory accreditation system, and a system of appropriate penalties

## **National Metrology Act**

- ⌚ **A National Metrology Board be created to be chaired by the Secretary of DOST with members from other government entities.**
- ⌚ **Representative from the business sector, professional metrology association and the academe shall also be appointed**
- ⌚ **ITDI is mandated to serve as the Board's secretariat and the**
- ⌚ **National Metrology Laboratory (NML) as the institute's laboratory arm is maintained and shall carry out the technical, calibration and laboratory functions to effectively implement the provisions of the act**

# **Thank You**



## APEC/APLMF Seminar on Automated Sphygmomanometers

**Current Position and Situation on  
Automated Sphygmomanometers in  
Chinese Taipei**  
July 21, 2006

## Introduction

- The Constitution of the Republic of China (Article 107) The Central Government shall have the power of legislation and administration over weights and measures matters.
- The BSMI is the regulatory authority for legal metrology in Chinese Taipei.

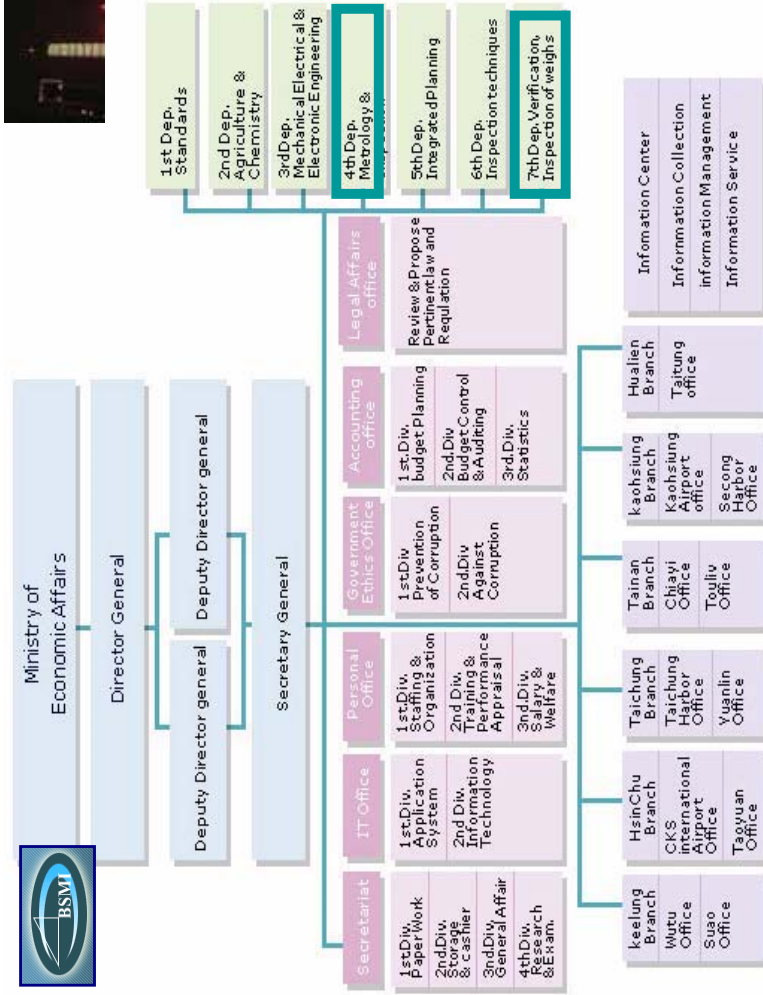

## Headquarters of the BSMI

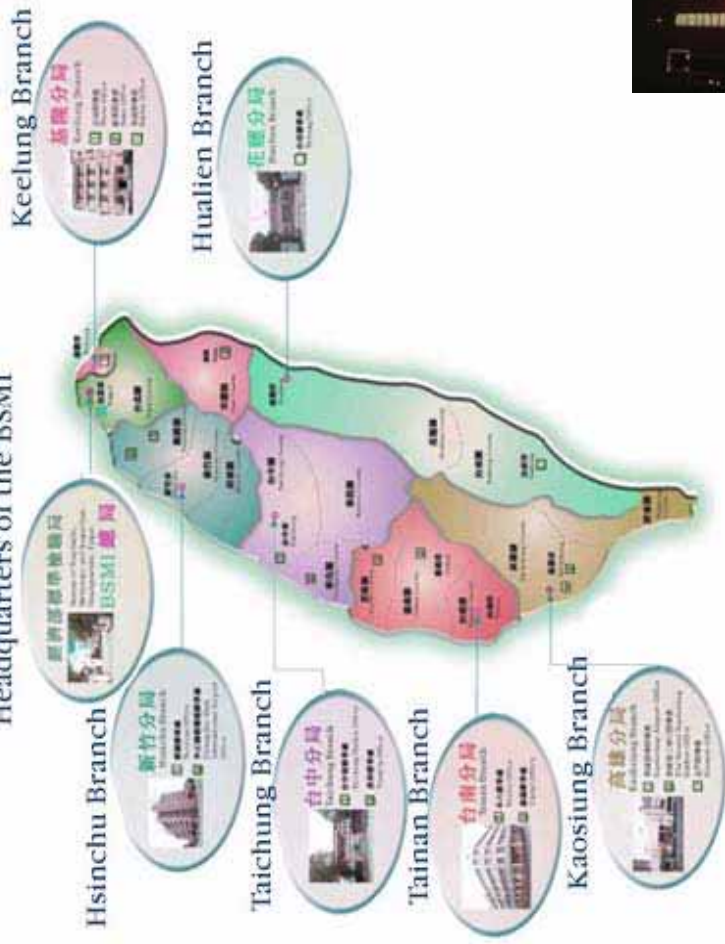



## Laws on Legal Measuring Instruments

- The Weights and Measures Act
- Enforcement Rules of Weights and Measures Act
- The Business Operation Licensing and Administration Regulations of Measuring Instrument Enterprises
- Regulations Governing Type Approval of Measuring Instruments
- Regulations Governing Verification and Inspection of Measuring Instruments
- Regulations Governing Commissioned Metrological Activities
- Regulations Governing Self-verification Conducted by Measuring Instrument Enterprises



## • Categories of Legal Measuring Instruments Subject to Verification (Regulations Governing Verification and Inspection of Measuring Instruments)

1. Taximeters;
2. Weighing instruments;
3. Mercury clinical thermometers.
4. Volumeters (including liquid dosage meters, diaphragm gas meters, water meters, oil meters, liquefied petroleum gas flow meters) ;
5. Milk hydrometers;
6. Electricity meters;



According to the **Business Operation Licensing and Administration Regulations of Measuring Instrument Enterprises** any person who engages in operating the business of **manufacturing, repairing or importing Sphygmomanometers** shall make application to the BSMI, obtain license and completed the procedures for business registration in accordance with relevant laws and regulations before commencing its business operations in our country.

- 7) Radar speedometers;
- 8) Sound level meters;
- 9) Concentration meters (including breathe alcohol testers and analyzers, rice moisture meters, vehicle exhausts emissions analyzers);
- 10) Illuminance meters;
- 11) Liquid column pressure gauges (including sphygmomanometers) ;



## Training Courses on Automated Sphygmomanometers

- The Seventh Department of BSMI held the training courses of Automated Sphygmomanometers, including practice according to OIML 16-2 (edition 2002) on November 8<sup>th</sup> to 9<sup>th</sup>, 2005.
- In the future, The training courses may be held every year.



## The Use of Automated Sphygmomanometers

- The amount of Sphygmomanometers imported from other countries is about 1 million pieces per year.
- The amount of Sphygmomanometers manufactured and used in Taiwan is about 0.5 million pieces.
- The amount of Automated Sphygmomanometers is more than 80 percent of total amount.



## Experiences on Automated Sphygmomanometers

- We only have the experiences to calibrate the pressure transducer of Automated Sphygmomanometers.



## The User on Automated Sphygmomanometers

- The typical user of Automated Sphygmomanometers is home users.
- The typical user is both used in the hospital and sold to the public.



## The Authority in Metrological Control

- The authority of the BSMI is responsible for issuing type approval certificates of Automated Sphygmomanometers for the healthy safety.



## Verification on Automated Sphygmomanometers

- According to the regulation of self-verification conducted by manufacture, the manufacture will self verify before selling in the market.
- According to the OIML R16-2(edition 2002), “Technical Specification for Verification and Inspection of Non-Invasive Automated Sphygmomanometers” had announced in Dec. 2005.
- The type approval and verification will be enforced by BSMI in Dec. 2009.



## Type Approval on Automated Sphygmomanometers

- The type approval on Automated Sphygmomanometers will be enforced in Dec. 2009.
- The marking of this number on the type approval will be stuck or marked on the body of Automated Sphygmomanometers.



## ➤ Technical Regulation

- The “Technical Specification for Verification and Inspection of Non-Invasive Automated Sphygmomanometers “ and “Technical Specification for Type Approval of Non-Invasive Automated Sphygmomanometers “ are all followed by the OIML R16-2 international recommendation.



# APEC/APLMP Seminar on Automated Sphygmomanometers

**Current Position and Situation on  
Automated Sphygmomanometers in  
Chinese Taipei**  
July 21, 2006

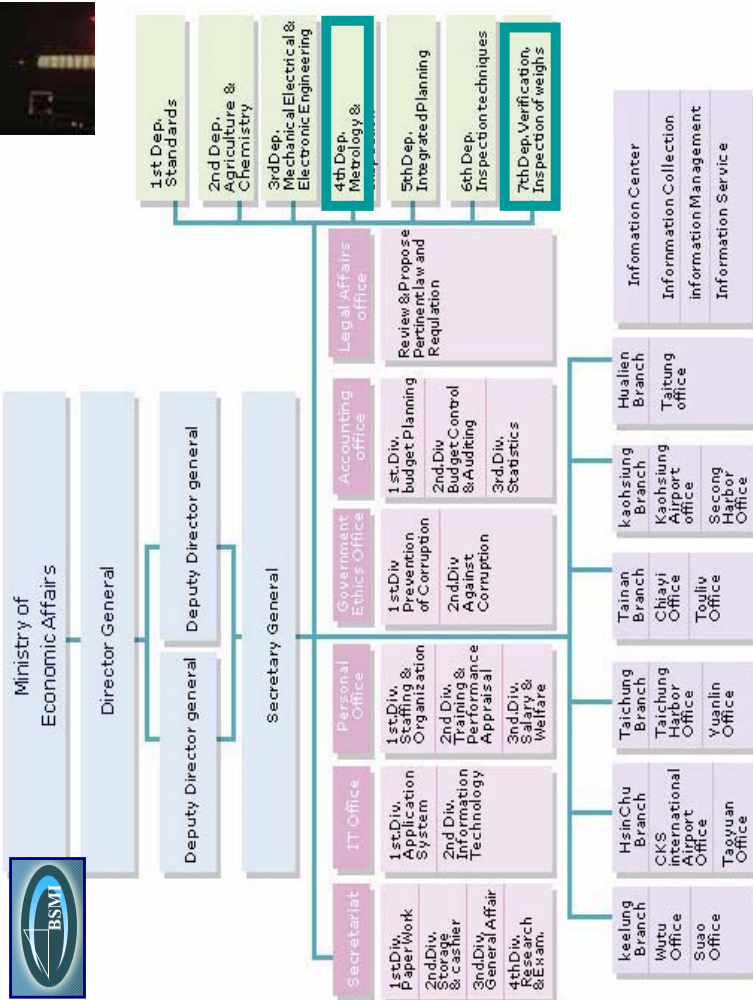
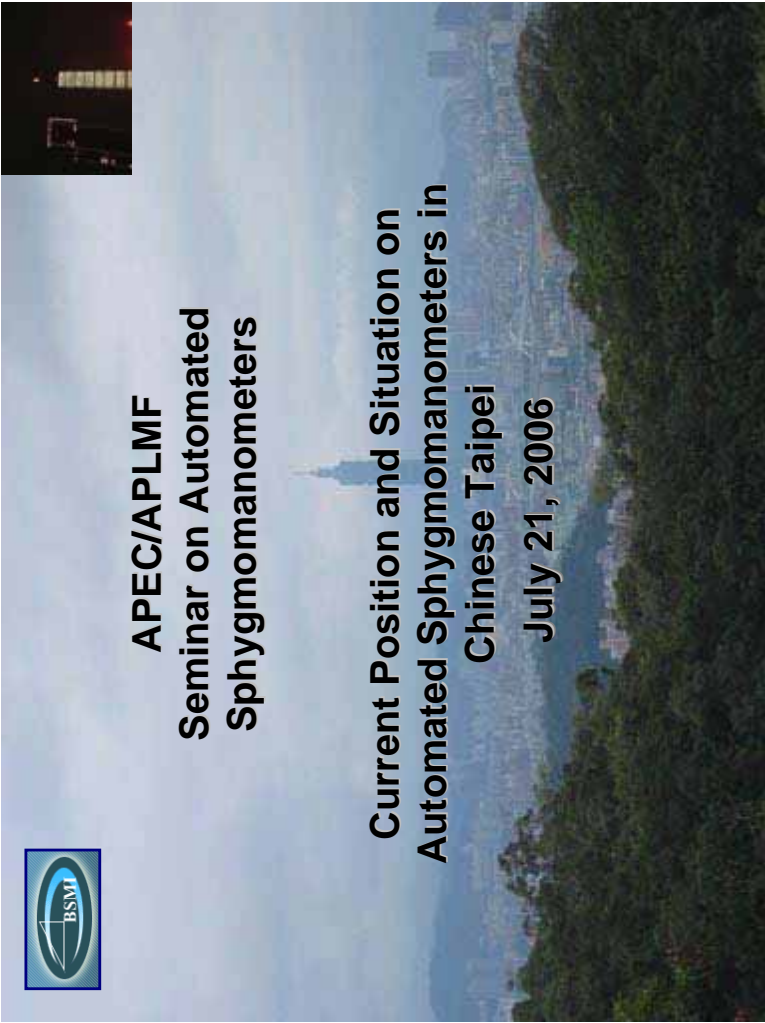

# Introduction

- The Constitution of the Republic of China (Article 107) The Central Government shall have the power of legislation and administration over weights and measures matters.
- The BSMI is the regulatory authority for legal metrology in Chinese Taipei.

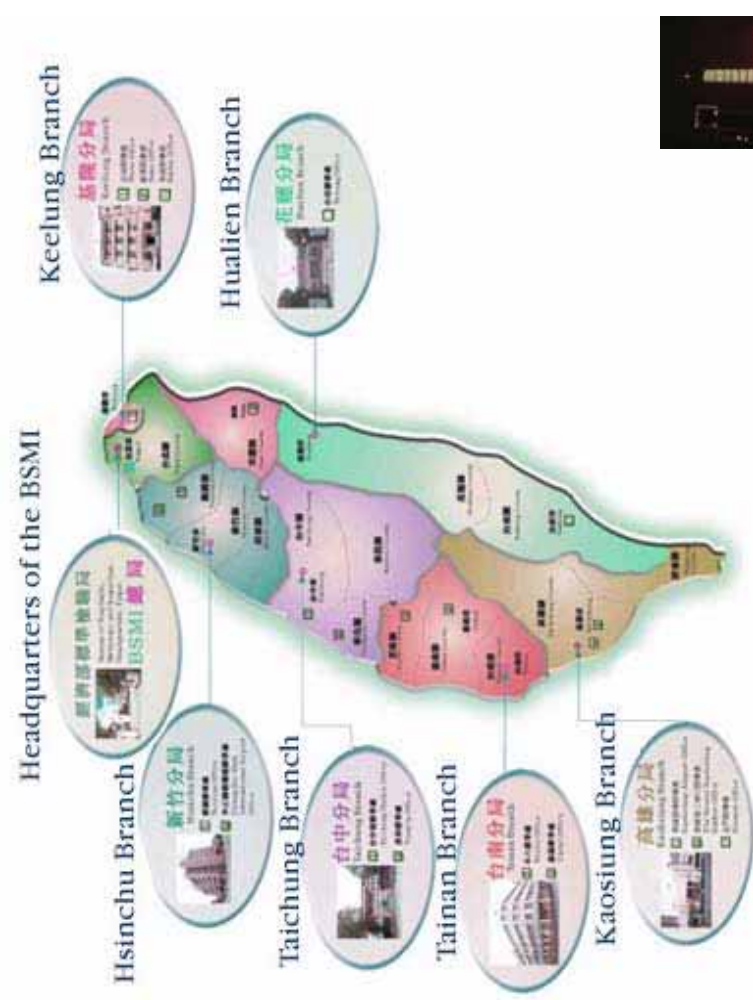
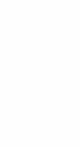





## Laws on Legal Measuring Instruments

- The Weights and Measures Act
- Enforcement Rules of Weights and Measures Act
- The Business Operation Licensing and Administration Regulations of Measuring Instrument Enterprises
- Regulations Governing Type Approval of Measuring Instruments
- Regulations Governing Verification and Inspection of Measuring Instruments
- Regulations Governing Commissioned Metrological Activities
- Regulations Governing Self-verification Conducted by Measuring Instrument Enterprises



## • Categories of Legal Measuring Instruments Subject to Verification (Regulations Governing Verification and Inspection of Measuring Instruments)

1. Taximeters;
2. Weighing instruments;
3. Mercury clinical thermometers.
4. Volumeters (including liquid dosage meters, diaphragm gas meters, water meters, oil meters, liquefied petroleum gas flow meters) ;
5. Milk hydrometers;
6. Electricity meters;



According to the **Business Operation**

## Licensing and Administration Regulations

of **Measuring Instrument Enterprises** any person who engages in operating the business of **manufacturing, repairing or importing Sphygmomanometers** shall make application to the BSMI, obtain license and completed the procedures for business registration in accordance with relevant laws and regulations before commencing its business operations in our country.



- 7) Radar speedometers;
- 8) Sound level meters;
- 9) Concentration meters (including breathe alcohol testers and analyzers, rice moisture meters, vehicle exhausts emissions analyzers);
- 10) Illuminance meters;
- 11) Liquid column pressure gauges (including sphygmomanometers) ;



## Training Courses on Automated Sphygmomanometers

- The Seventh Department of BSMI held the training courses of Automated Sphygmomanometers, including practice according to OIML 16-2 (edition 2002) on November 8<sup>th</sup> to 9<sup>th</sup>, 2005.
- In the future, The training courses may be held every year.



## The Use of Automated Sphygmomanometers

- The amount of Sphygmomanometers imported from other countries is about 1 million pieces per year.
- The amount of Sphygmomanometers manufactured and used in Taiwan is about 0.5 million pieces.
- The amount of Automated Sphygmomanometers is more than 80 percent of total amount.



## Experiences on Automated Sphygmomanometers

- We only have the experiences to calibrate the pressure transducer of Automated Sphygmomanometers.



## The User on Automated Sphygmomanometers

- The typical user of Automated Sphygmomanometers is home users.
- The typical user is both used in the hospital and sold to the public.



## The Authority in Metrological Control

- The authority of the BSMI is responsible for issuing type approval certificates of Automated Sphygmomanometers for the healthy safety.



## Verification on Automated Sphygmomanometers

- According to the regulation of self-verification conducted by manufacture, the manufacture will self verify before selling in the market.
- According to the OIML R16-2(edition 2002), “Technical Specification for Verification and Inspection of Non-Invasive Automated Sphygmomanometers” had announced in Dec. 2005.
- The type approval and verification will be enforced by BSMI in Dec. 2009.



## Type Approval on Automated Sphygmomanometers

- The type approval on Automated Sphygmomanometers will be enforced in Dec. 2009.
- The marking of this number on the type approval will be stuck or marked on the body of Automated Sphygmomanometers.



## ➤ Technical Regulation

- The “Technical Specification for Verification and Inspection of Non-Invasive Automated Sphygmomanometers “ and “Technical Specification for Type Approval of Non-Invasive Automated Sphygmomanometers “ are all followed by the OIML R16-2 international recommendation.



**Thank You**

**Web site:**

**<http://www.bsmi.gov.tw>**

**E-mail:**

**[metrology@bsmi.gov.tw](mailto:metrology@bsmi.gov.tw)**



# Who am I?

## Metrical control on Sphygmomanometers in Vietnam

*Presented by : Bui Trung Dung*

*DIRECTORATE FOR STANDARDS AND QUALITY  
STAMEQ – VIET NAM*

- ◆ My name is Bui Trung Dung, an expert of metrology managing, Metrology Department, Directorate for Standards and Quality of Vietnam (STAMEQ)
- ◆ My main job is to assess documents, approve patterns of different means of measurement to be imported and produced in Vietnam

## Brief introduction of juridical metrology in Vietnam

- ◆ The System of Legal Units of measurement in Vietnam is International System Units (SI)
- ◆ The Directorate for Standards and Quality is the state appropriate authority, which belongs to the Ministry of Science and Technology, takes responsibility to do consultant works for the government about measuring issues

## Brief introduction of juridical metrology in Vietnam

- ◆ Directorate for Standards and Quality (STAMEQ) is responsible for control and inspection of means of measurement in whole country.
- ◆ Branches of STAMEQ in provinces are in charge of control and inspection of ones in their locality.

## Organizations in STAMEQ

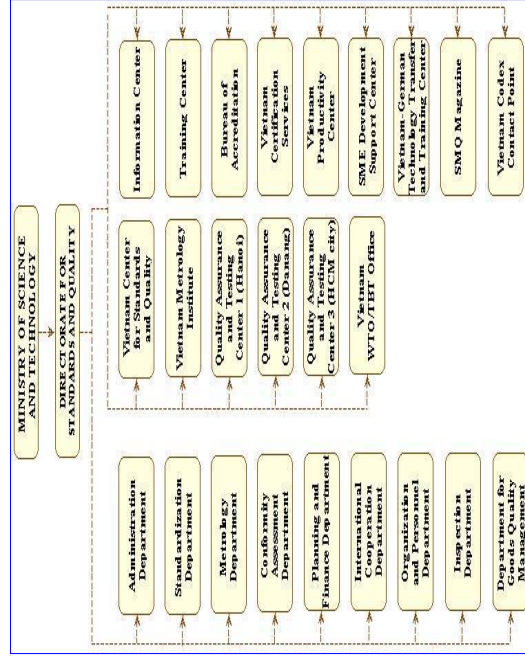

## Brief introduction of juridical metrology in Vietnam

- ◆ Directorate for Standards and Quality (STAMEQ) is responsible for control and inspection of means of measurement in whole country.
- ◆ Branches of STAMEQ in provinces are in charge of control and inspection of ones in their locality.

## The use of Automated Sphygmomanometers in Vietnam

- ◆ According to the statistical data in 2004, there are approximately over 38,000 sphygmomanometers used in the hospitals in Vietnam, including two groups of blood pressure equipment: non-automatic and automatic equipment
- ◆ Non-automatic equipment includes Mercury and Aneroid equipment which account for over 90% of the total number. The rest is automatic ones.

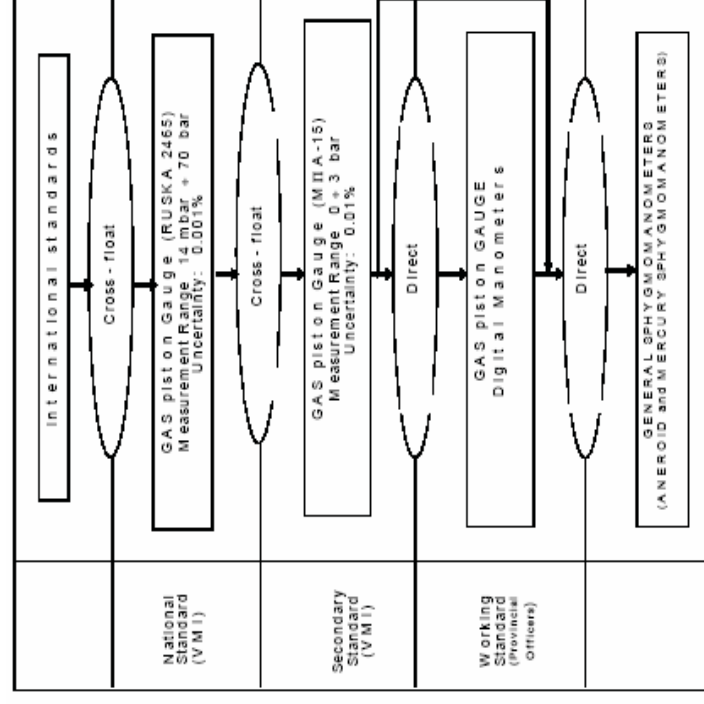

## Legislative control on Sphygmomanometers

- ◆ In Vietnam, the sphygmomanometers in the list of equipment to be verified
- ◆ Any organization or individual business, who wants to produce or import sphygmomanometers into Vietnam, has to take the pattern approval by the appropriate authority of Metrical Management.
- ◆ STAMEQ is the appropriate authority takes the duty to organize a pattern approving, measuring aspect controlling and inspecting for sphygmomanometers

## Expectation

- ◆ In near future, when the quantity of Automated Sphygmomanometers is increased in hospitals, clinics and households, we find the verification for these devices will be a very urgent task and will receive the special interest by the Government
- ◆ Researching on the application of recommendation OIML R16-2 and the related documents to edit the procedure of verification for automated sphygmomanometers are very necessary for the measuring management bodies in Vietnam

## Legislative control on Sphygmomanometers

- ◆ The sphygmomanometers have to be initially or subsequently verified at the state appropriate authority of verification.
- ◆ At present, We can only verify Aneroid and Mercury sphygmomanometers
- ◆ For the automated equipment, we are not able to deploy verification because most of the equipment are being used at households, so the need of verifying is not much. Further more, we don't have measuring standards and technical documents for verifying automated equipment.

## Acknowledgment

On behalf STAMEQ, Vietnam I would like to express my gratitude to APLMF secretariat and APEC secretariat and host country - Taiwan for their sponsorship and organizing this training Course

\*\*\*\*\*

**Thank you for your attention !**

# Metrical control on Sphygmomanometers in Vietnam

*Bui Trung Dung*

*Metrology Department of Directorate for Standards and Quality of VietNam (STAMEQ)*

*Good morning/afternoon everybody,*

My name is Bui Trung Dung, an expert of metrology managing, Metrology Department, Directorate for Standards and Quality of Vietnam.

My main job is to assess documents, approve patterns of different means of measurement to be imported and produced in Vietnam.

In my presentation, I would like to mention about the current use of Automated Sphygmomanometers in my country and the metrical control on Automated Sphygmomanometers in Vietnam.

## 1. Brief introduction of juridical metrology in Vietnam

Nowadays, the International System Units (SI) is admitted as the unique juridical system of Measurement in Vietnam and is allowed to use in the entire country by the Vietnamese government. The Directorate for Standards and Quality is the state appropriate

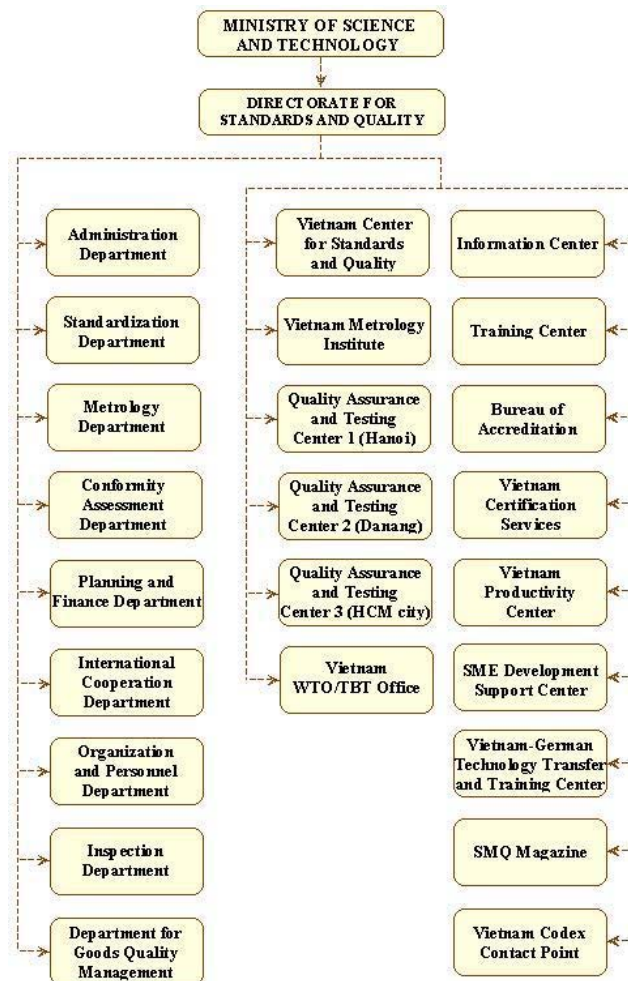

authority, which belongs to the Ministry of Science and Technology, takes responsibility to do consultant works for the government about measuring issues on the national scale including measuring units, national measuring standards system, and means of verification



and calibration as well as to represent Vietnam in international and regional meetings in the fields concerned.

## **2. Metrical control on Sphygmomanometers in Vietnam**

### **2.1. The use of Automated Sphygmomanometers in Vietnam**

Sphygmomanometers have been widely used to measure blood pressure of people in Vietnam for many years. According to the statistical data in 2004, there are approximately over 38,000 sphygmomanometers used in the hospitals in Vietnam, including two types of blood pressure equipment non-automatic and automatic equipment. Non-automatic equipment includes Mercury and Aneroid equipment which account for over 90% of the total number. The rest is automatic ones.

The non-automatic equipment are used fairly commonly in hospitals and health centers, but the automatic ones are not. There are many reasons for that situation. However, the main factor is that most of the equipment, which are being used in clinics are old types, not modern. Another important reason is that many of the Vietnamese medical personnel and doctors consider that automatic sphygmomanometers usually give the unstable results.

Nevertheless, automated sphygmomanometers are used commonly in families as home monitoring for its advantage of easy to use. For the people, who are high blood pressure, this type of equipment is very necessary for them to monitor their daily blood pressure stage. It is easy to buy an automated sphygmomanometer with a price from 30 - 100 USD in many medical equipment stores in Vietnam. Most of the equipment sold are imported to Vietnam from China, Malaysia, and Japan with different models and labels such as OMRON, Siemens, etc. The model OMRON RX-M2 is preferable in Vietnam for its good quality although the price is pretty high.

### **2.2. Legislative control on Sphygmomanometers in Vietnam**

As we know, sphygmomanometer is a mean of measurement relates to the health of people. Therefore, Vietnam has a regulation document (Numbered 65/2002/QD-BKHCNMT) stipulating sphygmomanometers in the list of equipment to be controlled by the state management, specifically, the appropriate authority of Metrical Management. Any organization or individual business, who wants to produce or import sphygmomanometers into Vietnam, has to take the pattern approval by the appropriate authority of Metrical Management.

The Directorate for Standards and Quality (STAMEQ) is the appropriate authority takes the duty to organize a pattern approving, measuring aspect controlling and inspecting for sphygmomanometers. We also decide whether an equipment have to be initially or subsequently verified at the state appropriate authority of verification.

At present, we can only verify the non-automated sphygmomanometers. Procedure of verification for Aneroid and Mercury sphygmomanometers is carried out on the technical document numbered 53:1999. Following is the traceable hierarchy for those devices implemented in Vietnam

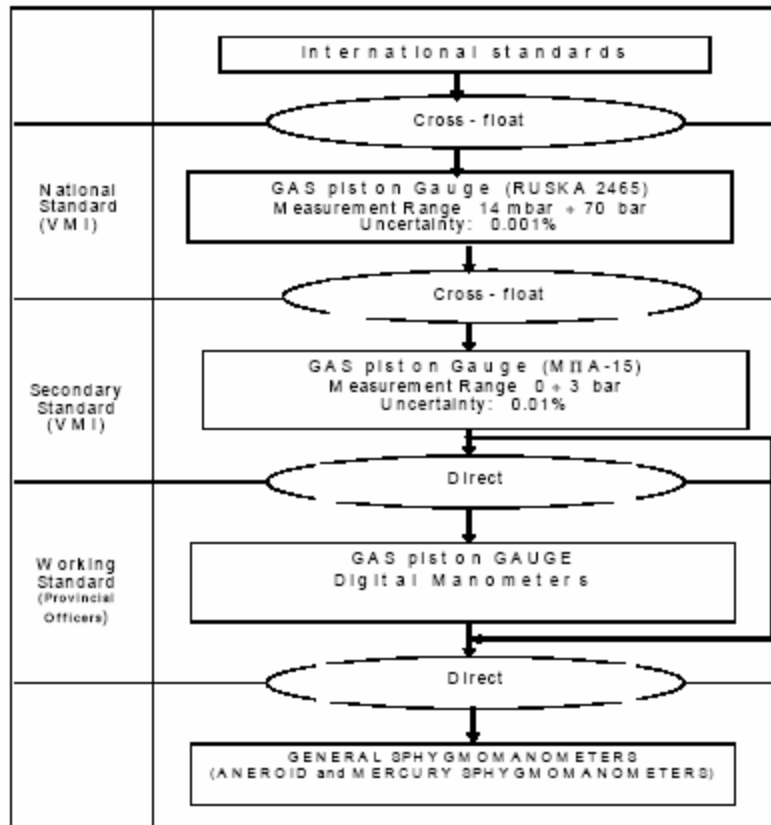

However, for the automated equipment, we are not able to deploy verification because most of the equipment are being used at households, so the need of verifying is not much. Further more, we don't have measuring standards and technical documents for verifying automated equipment.

### 3. Expectation

In near future, when the quantity of Automated Sphygmomanometers is increased in hospitals, clinics and households, we find the verification for these devices will be a very urgent task and will receive the special interest by the Government.

Researching on the application of recommendation OIML R16-2 and the related documents to edit the procedure of verification for automated sphygmomanometers are very necessary for the measuring management bodies in Vietnam.